



MANUFACTURED BY:
Backyard Discovery
3305 Airport Drive, Pittsburg, KS 66762
800-856-4445

Basepoint Business Centre: Rivermead Drive, Westlea, Swindon SN5 7EX Phone: 0800-118-2476
J.P. Coenstraat 7, The Bridge, The Hague, 2595 WP, Netherlands Phone: 0800-567-8990

SWEETWATER HEIGHTS PLAYHOUSE

MODEL # 2303027B

The assembly manual must be retained since it contains important information.



WARNING

Adult Assembly Required.

Not suitable for children under 2 years due to sharp points and small parts.

FOR DOMESTIC USE ONLY. INTENDED FOR OUTDOOR USE.

CAN ICES-003 (B)/NMB-003(B)



Please visit www.backyarddiscovery.com

For the most up to date assembly manual, to register your set, or to order replacement parts
Para obtener instrucciones en español, visite www.backyarddiscovery.com



**EASY STEP-BY-STEP
3D INTERACTIVE INSTRUCTIONS**

DOWNLOAD THE FREE APP



Made in China

INS-2303027B-A-SWEETWATER HEIGHTS-ENG 07/19/2023

Owner's Manual - Basic Setup Dimensions & Assembly Notes

Selecting the correct location for your play product is important for your children's safety and the product's longevity

- The safe play area refers to a zone extending 6'-7" (2m) beyond the play product on all sides, including the space above the play product.

SAFE PLAY AREA DIAGRAM

Ground Dimension

6'-3" [1.9 m] x 10'-1 1/4" [3.1 m]

Safe Play Area

19'-5" [5.9 m] x 23'-2 1/4" [7.1 m] x 14'-2 1/4" [4.3 m]

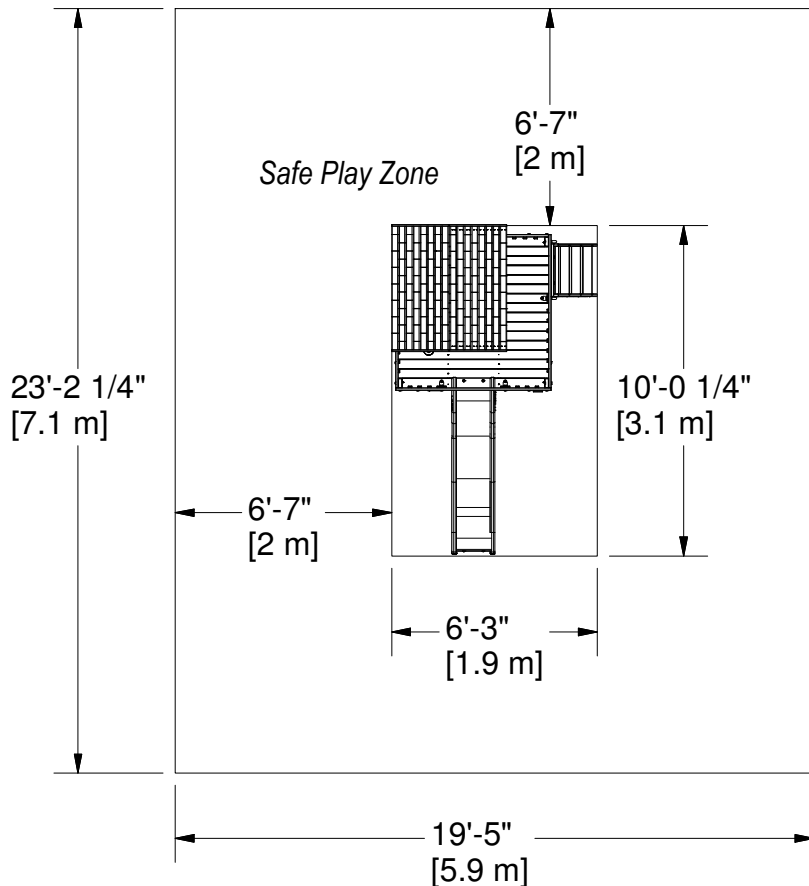

SAFE PLAY HEIGHT: 14'-2 1/4" [4.3m]
MAXIMUM FALL HEIGHT: 2'-11 3/4" [.9m]

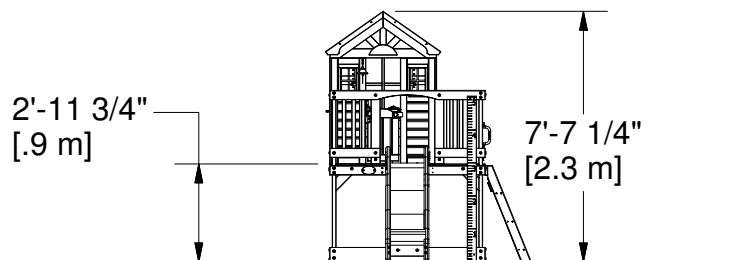

General Information:

Your set has been designed and engineered for children only and for residential use only.
A maximum of 150 lbs. per child is recommended for play activities designed for individual use.
A maximum of 120 lbs. per child is recommended for play activities designed for multiple child use.
A maximum of 6 children is recommended for this playhouse.

Owner's Manual - Parts Identification

Wood Components (Not to Scale)



E1 LEFT FRONT UPRIGHT - W4L17837
(x1) 1 3/8"x3 3/8"x62 3/8" (36x86x1584)

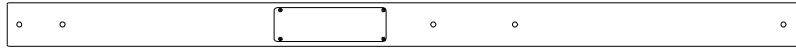

E2 RIGHT FRONT UPRIGHT - W2A03762
(x1) 1 3/8"x3 3/8"x62 3/8" (36x86x1584)



E3 RIGHT REAR UPRIGHT - W4L17839
(x1) 1 3/8"x3 3/8"x62 3/8" (36x86x1584)



E4 LEFT REAR UPRIGHT - W4L17840
(x1) 1 3/8"x3 3/8"x35" (36x86x889)



G1 GROUND BOARD - W4L17841
(x2) 1"x5 1/4"x56 3/4" (24x134x1442)



G2 GROUND BOARD - W4L17842
(x2) 1"x5 1/4"x54 7/8" (24x134x1394)



H1 FLOOR RAIL - W4L17845
(x2) 1"x3 3/8"x56 3/4" (24x86x1442)



H2 FLOOR RAIL - W4L17846
(x1) 1"x3 3/8"x54 7/8" (24x86x1394)



H3 COUNTER TOP SUPPORT - W4L17873
(x1) 1"x3 3/8"x8 3/8" (24x86x214)



H4 FLOOR RAIL - W4L17847
(x1) 1"x3 3/8"x54 7/8" (24x86x1394)



H5 FLOOR SUPPORT - W4L17848
(x2) 1"x3 3/8"x54 7/8" (24x86x1394)



H6 WALL RAIL - W4L17849
(x2) 1"x3 3/8"x18 1/2" (24x86x469)

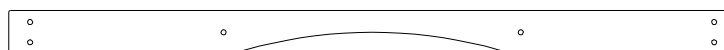

H7 WALL RAIL - W4L17850
(x1) 1"x3 3/8"x56 3/4" (24x86x1442)

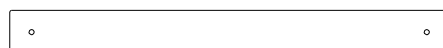

H8 WALL RAIL - W4L17851
(x1) 1"x3 3/8"x34 1/4" (24x86x871)

Owner's Manual - Parts Identification

Wood Components (Not to Scale)



H9 WALL RAIL - W4L17852
(x2) 1"x3 3/8"x16 5/8" (24x86x423)



H10 WALL RAIL - W4L17853
(x2) 1"x3 3/8"x16 3/4" (24x86x426)



H11 WALL RAIL - W4L17877
(x1) 1"x3 3/8"x55 7/8" (24x86x1418)



H20 DECK BRACE - W4L17854
(x8) 1"x3 3/8"x13" (24x86x330)



H76 LADDER RUNG - W4L17855
(x3) 1"x3 3/8"x18 1/8" (24x86x460)



H79 LEFT UPRIGHT - W4L17856
(x1) 1"x3 3/8"x38 3/8" (24x86x976)



H80 RIGHT UPRIGHT - W4L17857
(x1) 1"x3 3/8"x38 3/8" (24x86x976)



H110 ATTACHMENT BOARD - W4L17869
(x1) 1"x3 3/8"x19 1/4" (24x86x488)



J1 FLOOR SUPPORT BLOCK - W4L17858
(x3) 1"x3 3/8"x3 3/8" (24x86x86)



J3 COUNTER TOP SUPPORT - W4L17859
(x2) 1"x2 3/8"x9 1/4" (24x60x234)

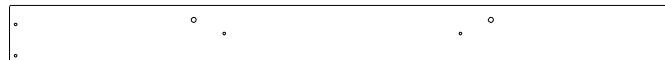

L1 FLOOR BOARD - W4L17860
(x1) 5/8"x4 3/8"x52" (16x112x1321)



L2 FLOOR BOARD - W4L17861
(x1) 5/8"x4 3/8"x54 3/8" (16x112x1382)

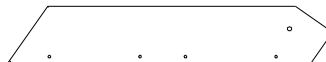

L3 GABLE BOARD - W4L17862
(x4) 5/8"x4 3/8"x25 3/8" (16x112x644)



M1 GROWTH BOARD - W4L17864
(x1) 5/8"x3 3/8"x60 1/4" (16x86x1530)

Owner's Manual - Parts Identification

Wood Components (Not to Scale)

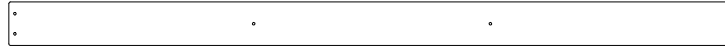

M4 FLOOR BOARD - W4L17865
(x13) 5/8"x3 3/8"x56 3/4" (16x86x1442)



M6 FLOOR BOARD - W4L17843
(x1) 5/8"x3 3/8"x56 3/4" (16x86x1442)



M7 WALL BOARD - W4L17844
(x2) 5/8"x3 3/8"x26 1/2" (16x86x673)



M10 WALL BOARD - W4L17866
(x1) 5/8"x3 3/8"x26 1/2" (16x86x673)



M33 FASCIA BOARD - W4L17867
(x4) 5/8"x3 3/8"x25 5/8" (16x86x652)



M73 REAR SUPPORT - W4L17868
(x1) 5/8"x3 3/8"x19 1/4" (16x86x488)



M77 SLIDE BRACE - W4L13297
(x1) 5/8"x3 3/8"x14 1/4" (16x86x362)



M78 SLIDE BRACE - W4L13298
(x1) 5/8"x3 3/8"x14 1/4" (16x86x362)



N2 WINDOW SHELF - W4L17871
(x2) 5/8"x2 3/8"x19 1/8" (16x60x485)

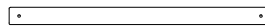

O1 PICKET - W4L17872
(x19) 5/8"x1 3/8"x20 1/2" (16x34x520)

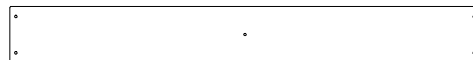

Q1 COUNTER TOP - W4L17863
(x2) 1"x4 3/8"x36 3/4" (24x112x934)

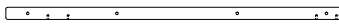

S1 RAIL BOARD - W4L17874
(x2) 1"x1"x26 3/4" (24x24x679)

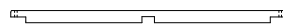

S2 WINDOW TRIM - W4L17875
(x2) 1"x1"x21 1/2" (24x24x545)



S3 WINDOW TRIM - W4L17876
(x2) 1"x1"x23 3/8" (24x24x594)

Owner's Manual - Parts Identification

Wood Components (Not to Scale)

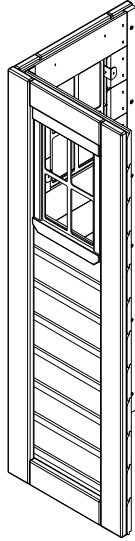

WP1 FRONT RIGHT CORNER PANEL - W2A03848
(x1)

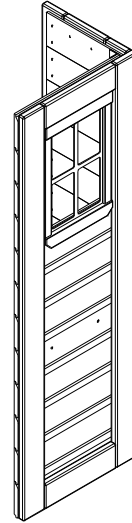

WP2 REAR RIGHT CORNER PANEL - W2A03851
(x1)

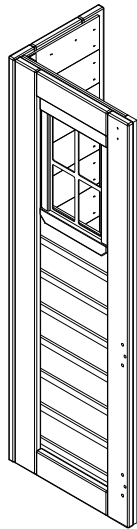

WP3 FRONT LEFT CORNER PANEL - W2A03854
(x1)

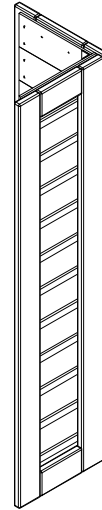

WP4 REAR LEFT CORNER PANEL - W2A03857
(x1)

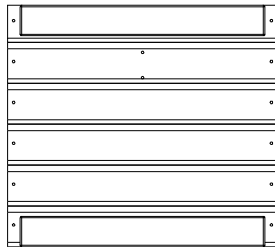

WP5 REAR CENTER PANEL - W2A03860
(x1) 1 1/4"x18 7/8"x20 7/8" (32x478x536)

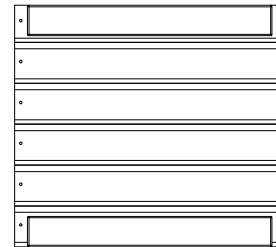

WP6 LEFT CENTER PANEL - W2A03861
(x1) 1 1/4"x18 7/8"x20 7/8" (32x478x536)

Owner's Manual - Parts Identification

Wood Components (Not to Scale)

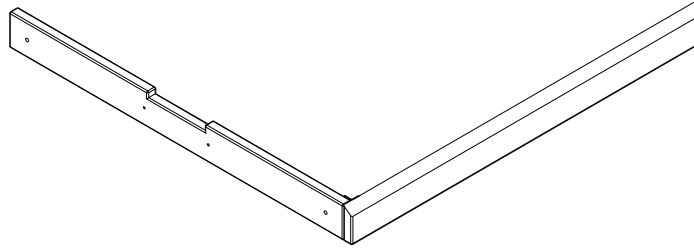

WP8 HEADER ASSEMBLY - W2A03862

(x2)

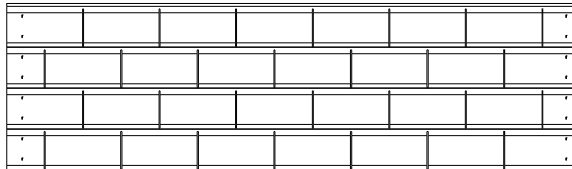

RP1 LOWER ROOF PANEL - W2A03863

(x2) 1 3/8"x13"x44 7/8" (35x329x1140)



RP2 UPPER ROOF PANEL - W2A03864

(x2) 1 3/8"x12 3/4"x44 7/8" (35x324x1140)

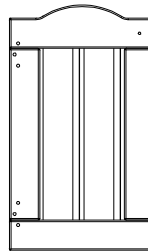

DP1 RIGHT DOOR PANEL - W2A03865

(x1) 1 1/8"x19 1/8"x11 3/8" (27x486x288)

Owner's Manual - Parts Identification

Hardware Components

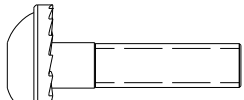

H100171 BOLT WH BLK
(x6) 1/4x1

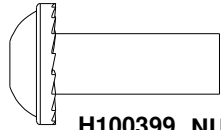

H100399 NUT BARREL WH BLK
(x4) 1/4x7/8

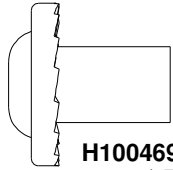

H100469 NUT BARREL WH BLK
(x7) 5/16x5/8

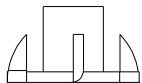

H100398 T-NUT BLK
(x2) 1/4

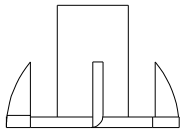

H100379 T-NUT BLK
(x40) 5/16

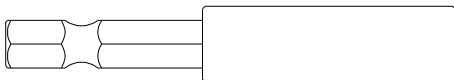

H101100 MAGNETIC DRIVER
(x1)

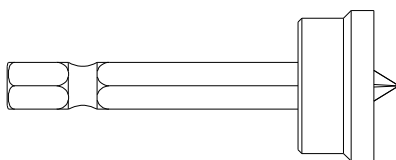

H100764 SCREW SETTER
(x1)

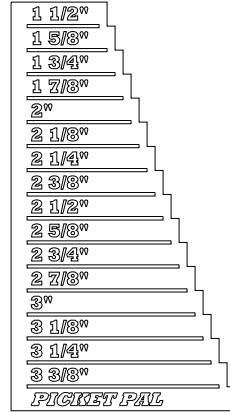

A6P00410 PICKET PAL
(x1)



H100484 BOLT WH BLK
(x3) 5/16x3 1/4

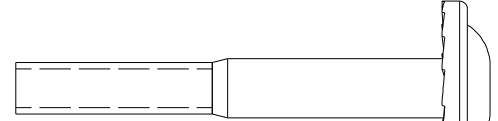

H100205 BOLT WH BLK
(x14) 5/16x2-1/4

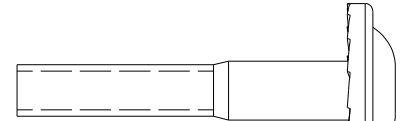

H100378 BOLT WH BLK
(x10) 5/16x1 3/4

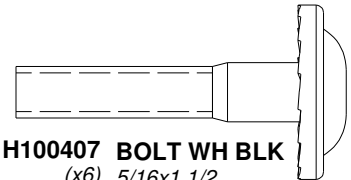

H100407 BOLT WH BLK
(x6) 5/16x1 1/2



H100468 BOLT WH BLK
(x4) 5/16x1

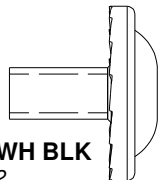

H100396 BOLT WH BLK
(x10) 5/16x1/2

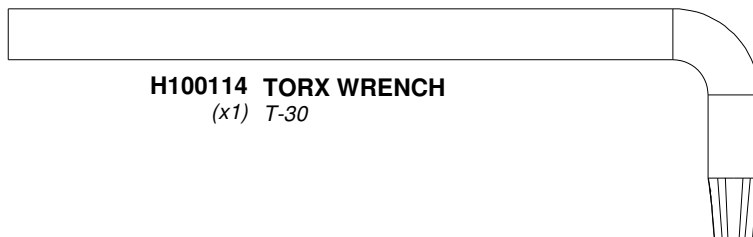

H100114 TORX WRENCH
(x1) T-30



H100147 TORX BIT
(x1) T-30

Owner's Manual - Parts Identification

Hardware Components



H100395 SCREW PFH BLK
(x37) 8x3/4

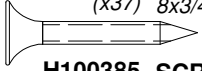

H100385 SCREW PFH BLK
(x26) 8x1

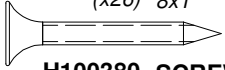

H100380 SCREW PFH BLK
(x42) 8x1 1/8

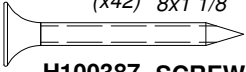

H100387 SCREW PFH BLK
(x30) 8x1 1/4

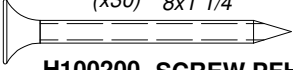

H100200 SCREW PFH BLK
(x134) 8x1 1/2

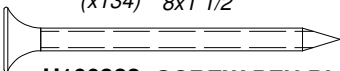

H100382 SCREW PFH BLK
(x9) 8x1 3/4

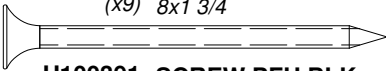

H100391 SCREW PFH BLK
(x20) 8x2

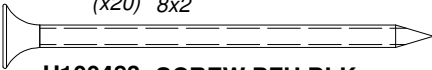

H100483 SCREW PFH BLK
(x3) 8x2 1/4

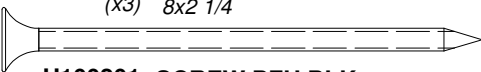

H100201 SCREW PFH BLK
(x28) 8x2-1/2

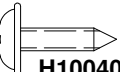

H100408 SCREW PWH BLK
(x8) 8x1/2

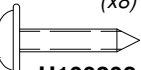

H100202 SCREW PWH BLK
(x12) 8x5/8

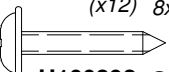

H100392 SCREW PWH BLK
(x8) 8x3/4

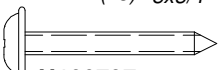

H100797 SCREW PWH BLK
(x6) 8x1

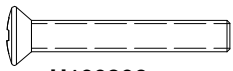

H100806 SCREW POH BLK
(x12) 8/32x1 1/8



H100804 T-NUT
(x12) 8/32

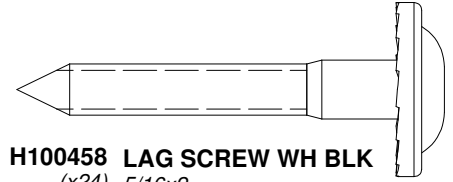

H100458 LAG SCREW WH BLK
(x24) 5/16x2

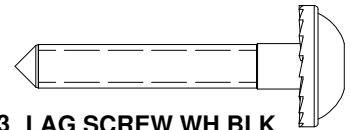

H100403 LAG SCREW WH BLK
(x10) 1/4x1 1/2

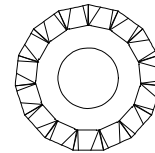

H100198 WASHER LOCK EXT BLK
(x57) 8x19

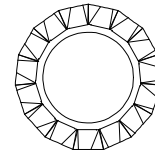

H100199 WASHER LOCK EXT BLK
(x7) 12x19

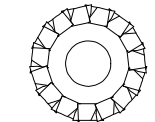

H100405 WASHER LOCK EXT BLK
(x16) 6x15

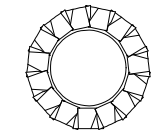

H100400 WASHER LOCK EXT BLK
(x4) 8x15

Owner's Manual - Parts Identification

Accessory Components (Not to Scale)

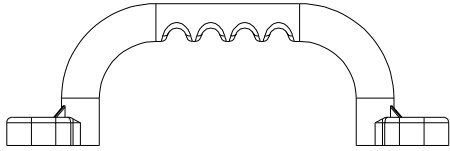

A6P00654
(x2) **HAND GRIP GREY PLASTIC**

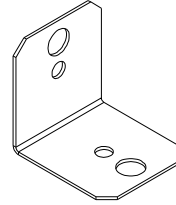

A4M00555
(x8) **90° L-BRACKET - BLK**

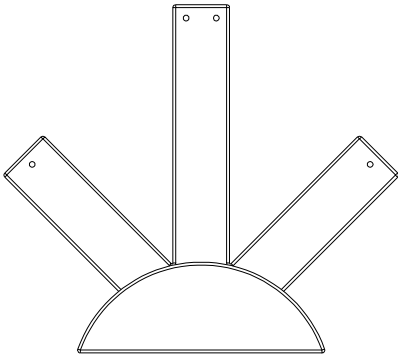

A100361
(x2) **PLASTIC SUNBURST**



A4M00528
(x1) **BYD ID TAG (MEDIUM) AGES 2 TO 10**

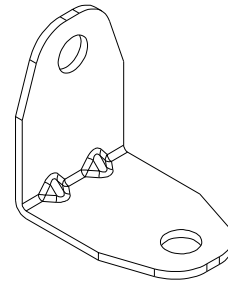

A4M01047
(x3) **L BRACKET 2.5x38x55x55**

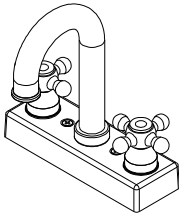

A6P00024
(x1) **FAUCET KIT**

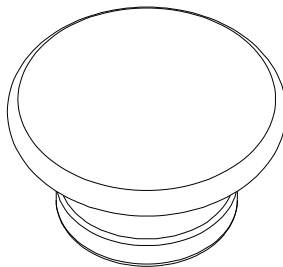

A6P00067
(x1) **KNOB - BLK**

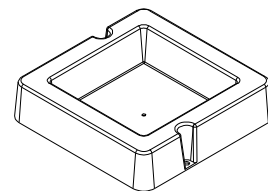

A6P00032
(x1) **SURFACE MOUNT BASIN**



A100178
(x4) **AUGER GROUND STAKE**

Owner's Manual - Parts Identification

Accessory Components (Not to Scale)

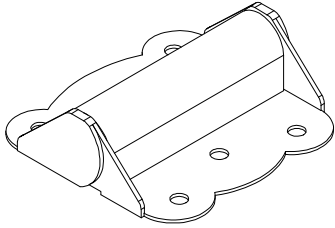

A4M00624
(x1) HINGE (DOOR, SPRING LOADED)

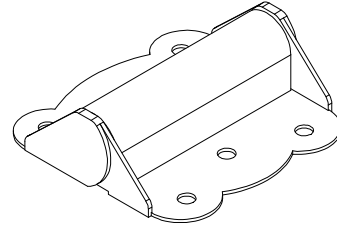

A4M00994
(x1) HINGE (DOOR, NON-SPRING LOADED)

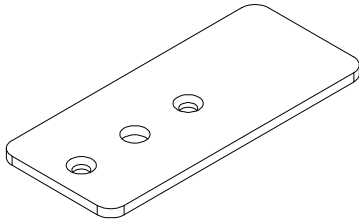

A4M00933
(x1) DOOR STOP

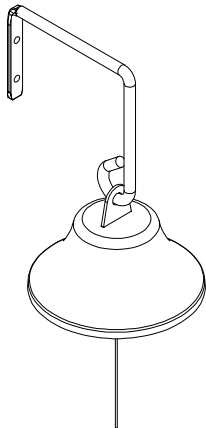

A4M01045
(x1) BELL ASSEMBLY

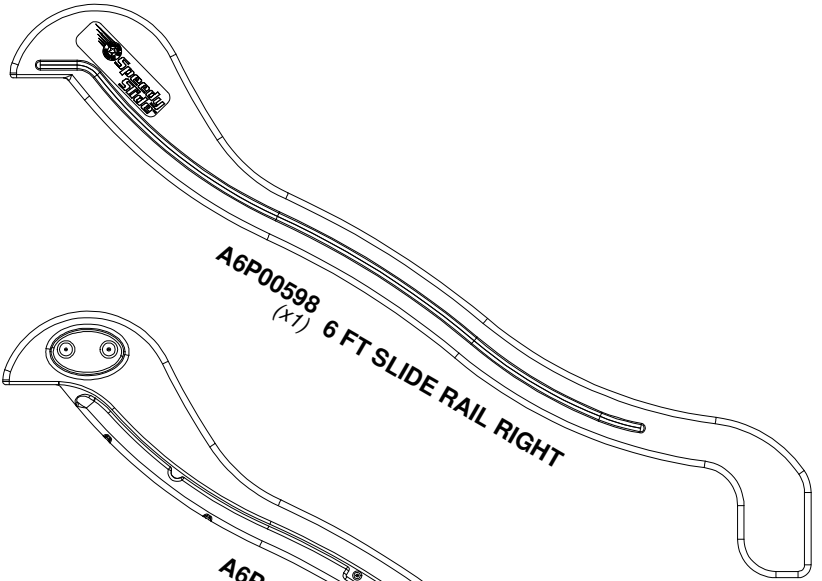

A6P00598
(x1) 6 FT SLIDE RAIL RIGHT

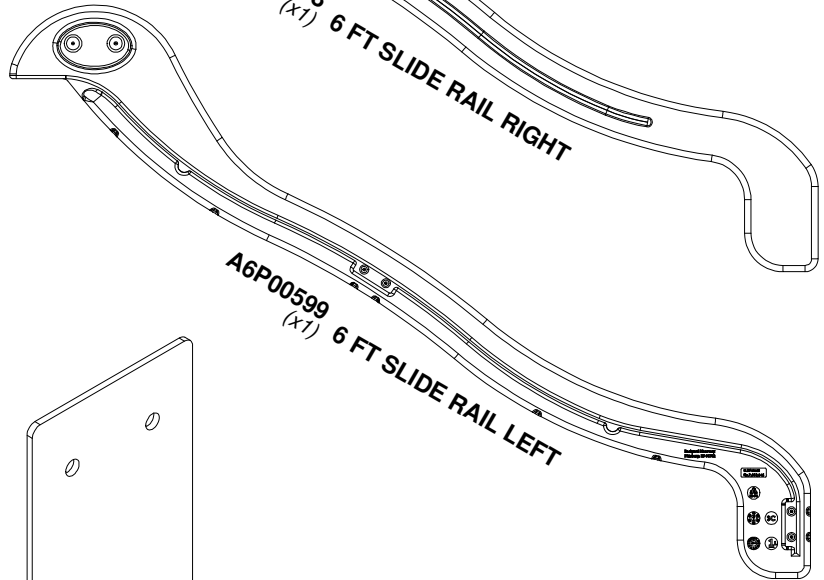

A6P00599
(x1) 6 FT SLIDE RAIL LEFT

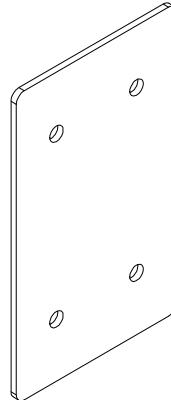

A4M00997
(x8) METAL CLEAT



A6P00597
(x1) 6 FT SLIDE BED

Owner's Manual - Parts Identification

Accessory Components (Not to Scale)

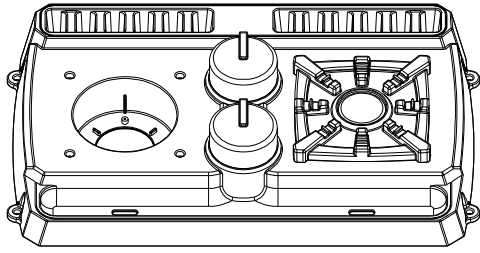

A6P00335
(x1) **STOVE BASE**

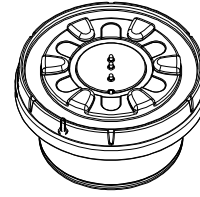

A6P00330
(x1) **INDUCTIVE BURNER KIT**

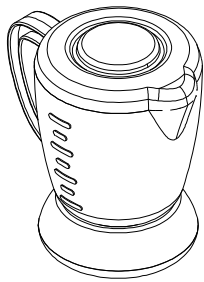

A6P00331
(x1) **BLENDER**

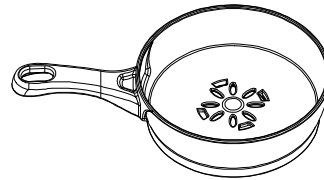

A6P00338
(x1) **FRY PAN**

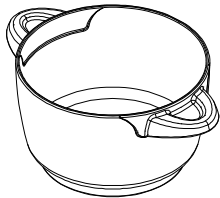

A6P00336
(x1) **BOIL POT**

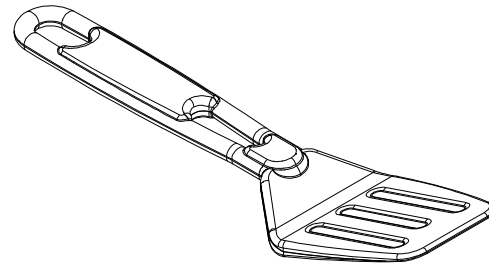

A6P00339
(x1) **SPATULA**

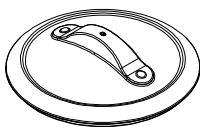

A6P00337
(x2) **POT/PAN LID**

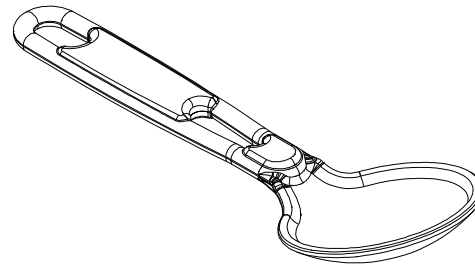

A6P00340
(x1) **LADLE**

PRE-ASSEMBLY STEP 1 - SORTING PARTS

It is critical for ease of assembly that you take the time to sort and organize the wood and hardware.

WOOD PARTS:

- Organize wood parts by the three-digit, alpha-numeric number stamped on each board (ex. P01).
- If there are multiple boards with the same stamped number, stack those pieces together.
- Stamps can be found on the flat surface of the boards or on the end of the boards.
- Allow yourself plenty of room - the wood pieces can take up a significant amount of space.

NOTE: CARTONS ARE NOT ORGANIZED BY BOARD NUMBER.

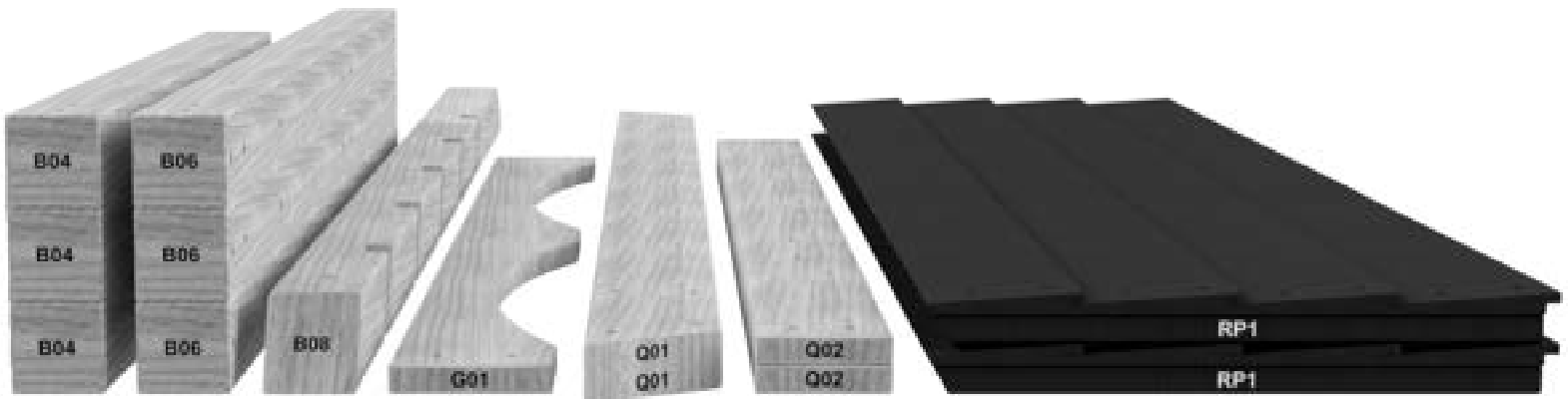

HARDWARE PARTS:

- We recommend that you have a separate table to organize the hardware.
- Hardware bags are printed with a seven-digit, alpha-numeric part number.
- You can organize your hardware by part number or group by hardware type (i.e. bolts, nuts, etc.).
- During assembly you only need to reference the last four digits of the number.

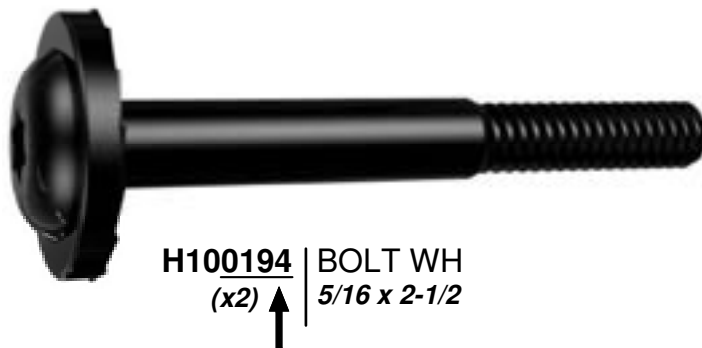

PRE-ASSEMBLY STEP 2 - TOOLS REQUIRED



Cordless Drill or
Electric Drill

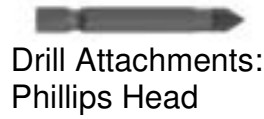

Drill Attachments:
Phillips Head



1/8", 3/16", 3/8" & 7/16"
Drill Bits



Phillips Screw Driver



Open End Wrenches 1/2" & 9/16"



3/8" Drive Ratchet, 1/2" &
9/16" STD Sockets 1/2" & 9/16"
Deep Sockets



Claw Hammer



Rubber Mallet - Optional



Tape Measure

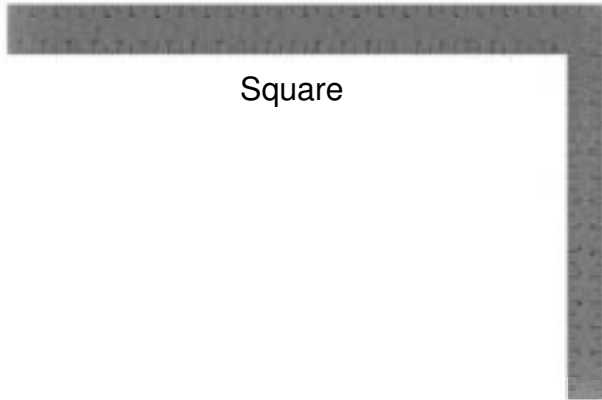

Square



Level 24"

ELECTRONICS SAFETY WARNING

Note:

This equipment has been tested and found to comply with the limits for a Class B digital device, pursuant to part 15 of the FCC Rules. These limits are designed to provide reasonable protection against harmful interference in a residential installation. This equipment generates, uses and can radiate radio frequency energy and, if not installed and used in accordance with the instructions, may cause harmful interference to radio communications. However, there is no guarantee that interference will not occur in a particular installation. If this equipment does cause harmful interference to radio or television reception, which can be determined by turning the equipment off and on, the user is encouraged to try to correct the interference by one or more of the following measures:

- Reorient or relocate the receiving antenna.
- Increase the separation between the equipment and receiver.
- Connect the equipment into an outlet on a circuit different from that to which the receiver is connected.
- Consult the dealer or an experienced radio/TV technician for help

Caution: Changes or modifications not expressly approved by the party responsible for compliance could void the user's authority to operate the equipment.

PRE-ASSEMBLY STEP 3 - CHOOSE YOUR ASSEMBLY METHOD

There are several types of assembly instructions available to you.

1. Printed Assembly Manual included with your set
2. BILT APP - 3D interactive instructions
3. Combination of the Printed Manual and BILT APP (Note: Step numbers can differ between the two methods)

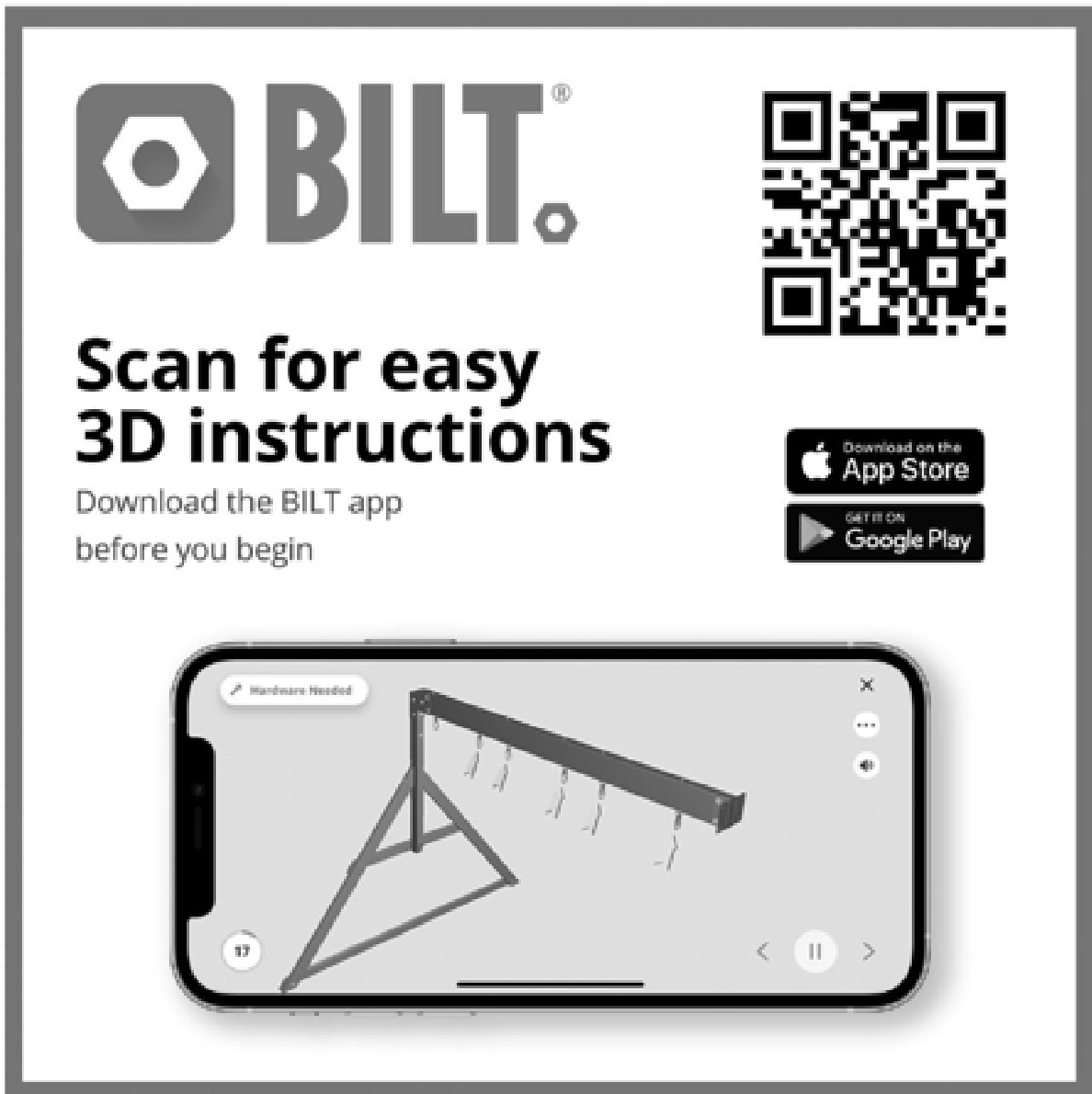

BILT.

Scan for easy
3D instructions

Download the BILT app
before you begin

Download on the
App Store

Get it on
Google Play

Hardware Needed

17

< || >

STEP 1 - LADDER ASSEMBLY

QTY	PART NUMBER	DESCRIPTION
6	H100391	SCREW PFH 8x2 BLK

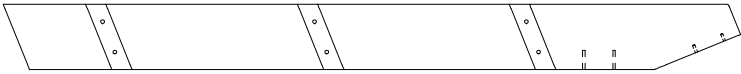

H79 | LEFT UPRIGHT - W4L17856
(x1) | 1"x3 3/8"x38 3/8" (24x86x976)



H76 | LADDER RUNG - W4L17855
(X3) | 1"x3 3/8"x18 1/8" (24x86x460)

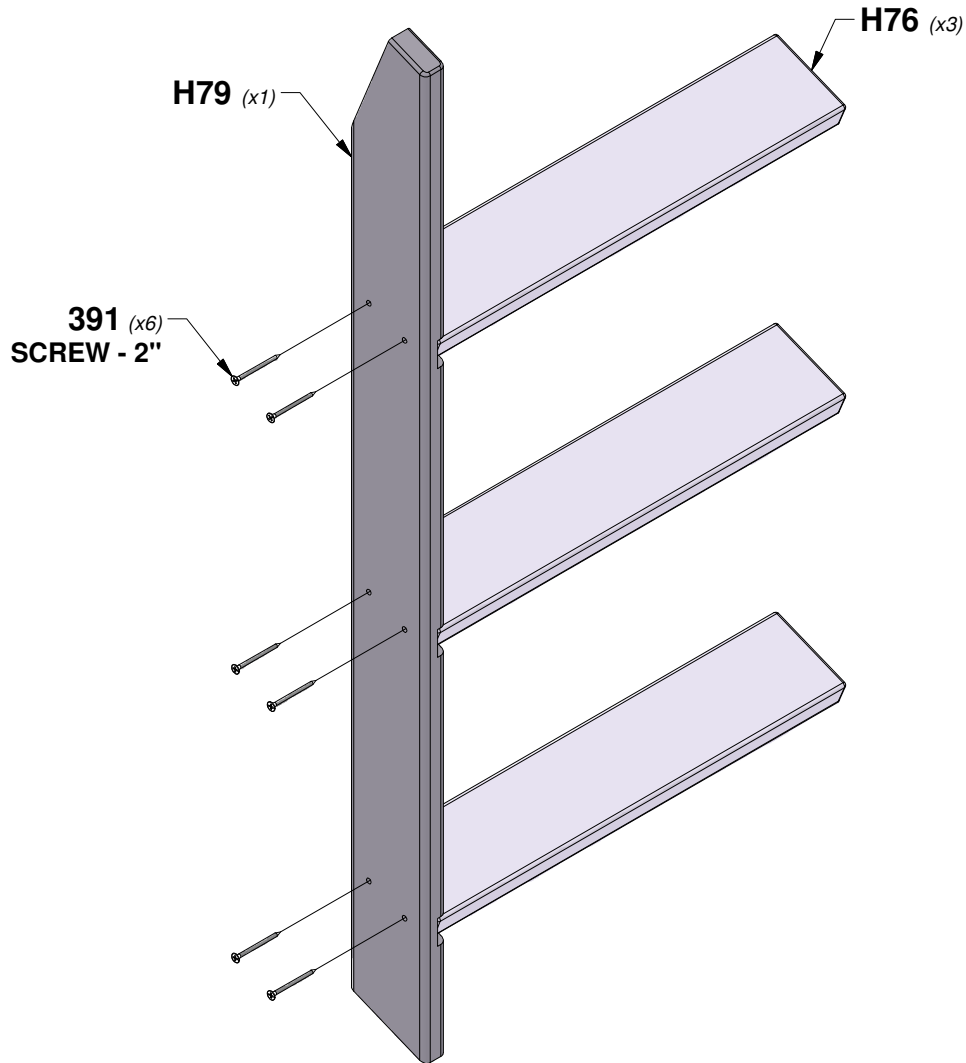

STEP 2 - LADDER ASSEMBLY

QTY	PART NUMBER	DESCRIPTION
6	H100391	SCREW PFH 8x2 BLK



H80 | RIGHT UPRIGHT - W4L17857
(x1) | 1"x3 3/8"x38 3/8" (24x86x976)

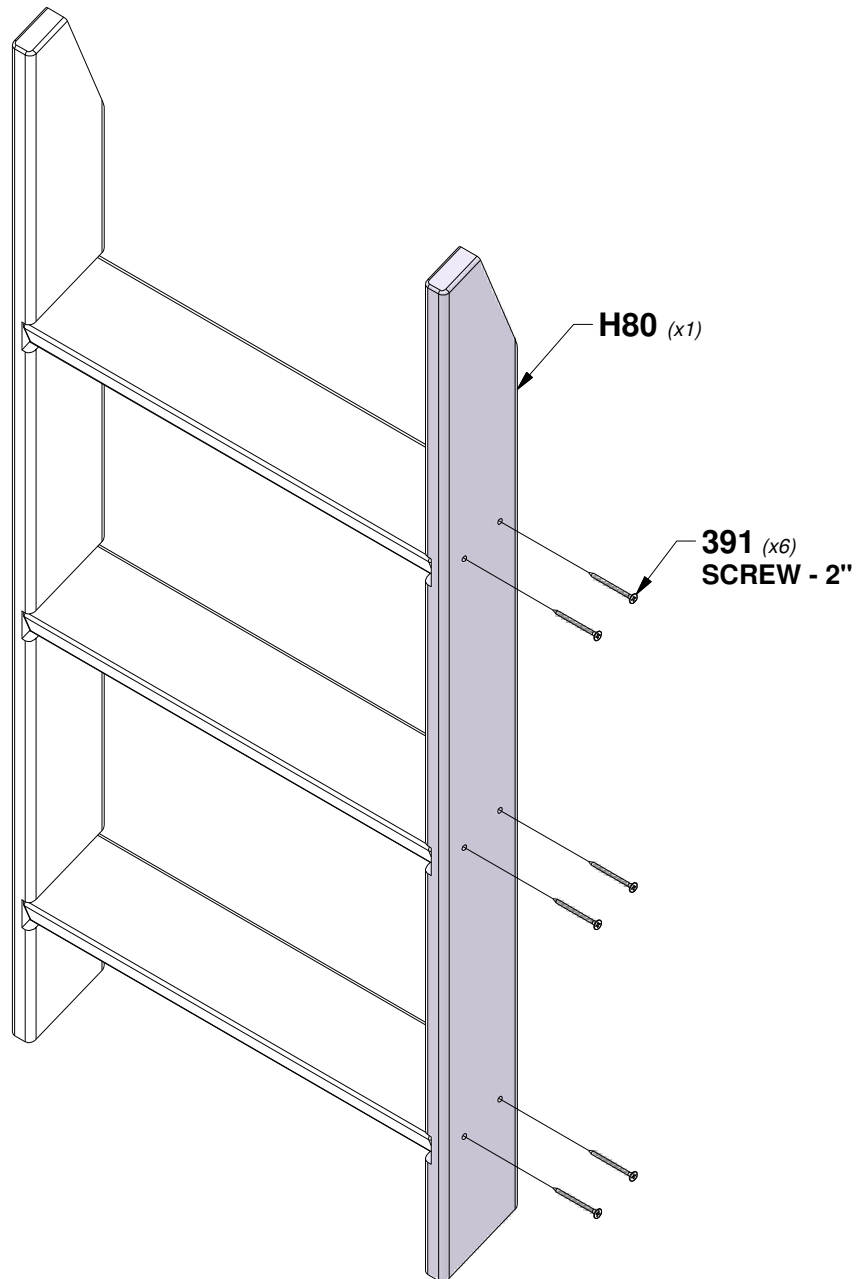

STEP 3 - LADDER ASSEMBLY

QTY	PART NUMBER	DESCRIPTION
4	H100391	SCREW PFH 8x2 BLK



M73 | REAR SUPPORT - W4L17868
(x1) | 5/8"x3 3/8"x19 1/4" (16x86x488)

NOTE:
USE PILOT HOLES.

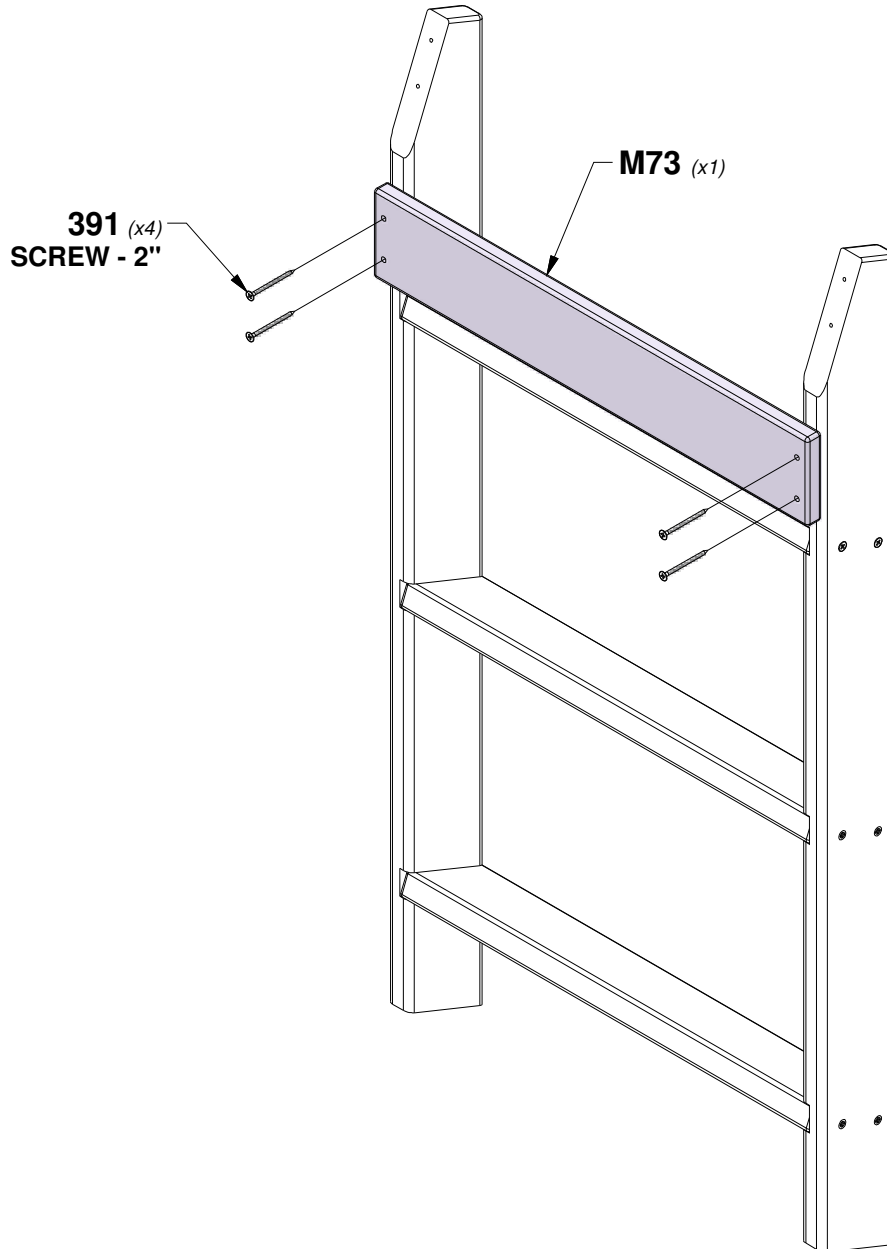

STEP 4 - LADDER ASSEMBLY

QTY	PART NUMBER	DESCRIPTION
4	H100391	SCREW PFH 8x2 BLK



H110 | ATTACHMENT BOARD - W4L17869
(x1) | 1"x3 3/8"x19 1/4" (24x86x488)

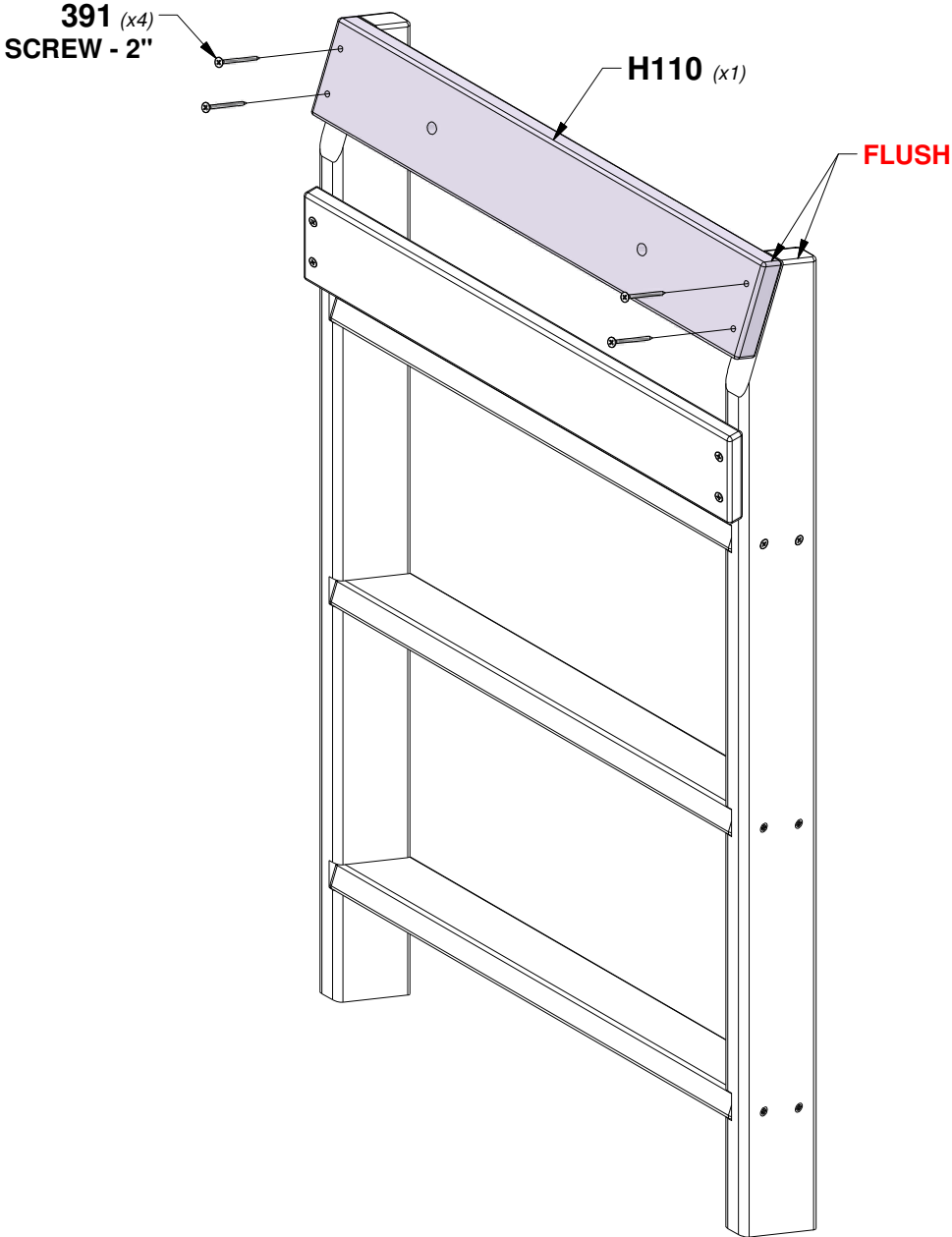

STEP 1 - SLIDE

QTY	PART NUMBER	DESCRIPTION
2	H100379	T-NUT 5/16 BLK
2	H100396	BOLT WH 5/16x1/2 BLK



A6P00597
(x1) **6 FT SLIDE BED**



M77 SLIDE BRACE - W4L13297
(x1) 5/8"x3 3/8"x14 1/4" (16x86x362)

NOTE:
PLACE 'M77' SLIDE BRACE BOARD 1/2" FROM THE BOTTOM EDGE OF THE SLIDE BED. USING THE BOARD AS A TEMPLATE, MARK WHERE THE PILOT HOLES WILL BE DRILLED. USE A 3/8" DRILL BIT TO DRILL THE PILOT HOLES INTO THE SLIDE BED. ATTACH THE SLIDE BED SUPPORT BOARD USING THE HARDWARE PROVIDED.

TIP:
PRE-BENDING THE ENDS WILL EASE ASSEMBLY. PLACING THE SLIDE BED OUT IN THE SUN MAKES IT EASIER TO BEND.

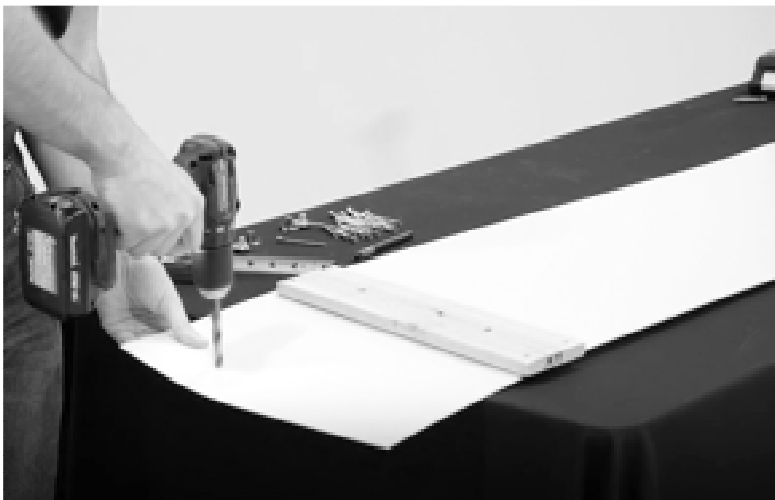
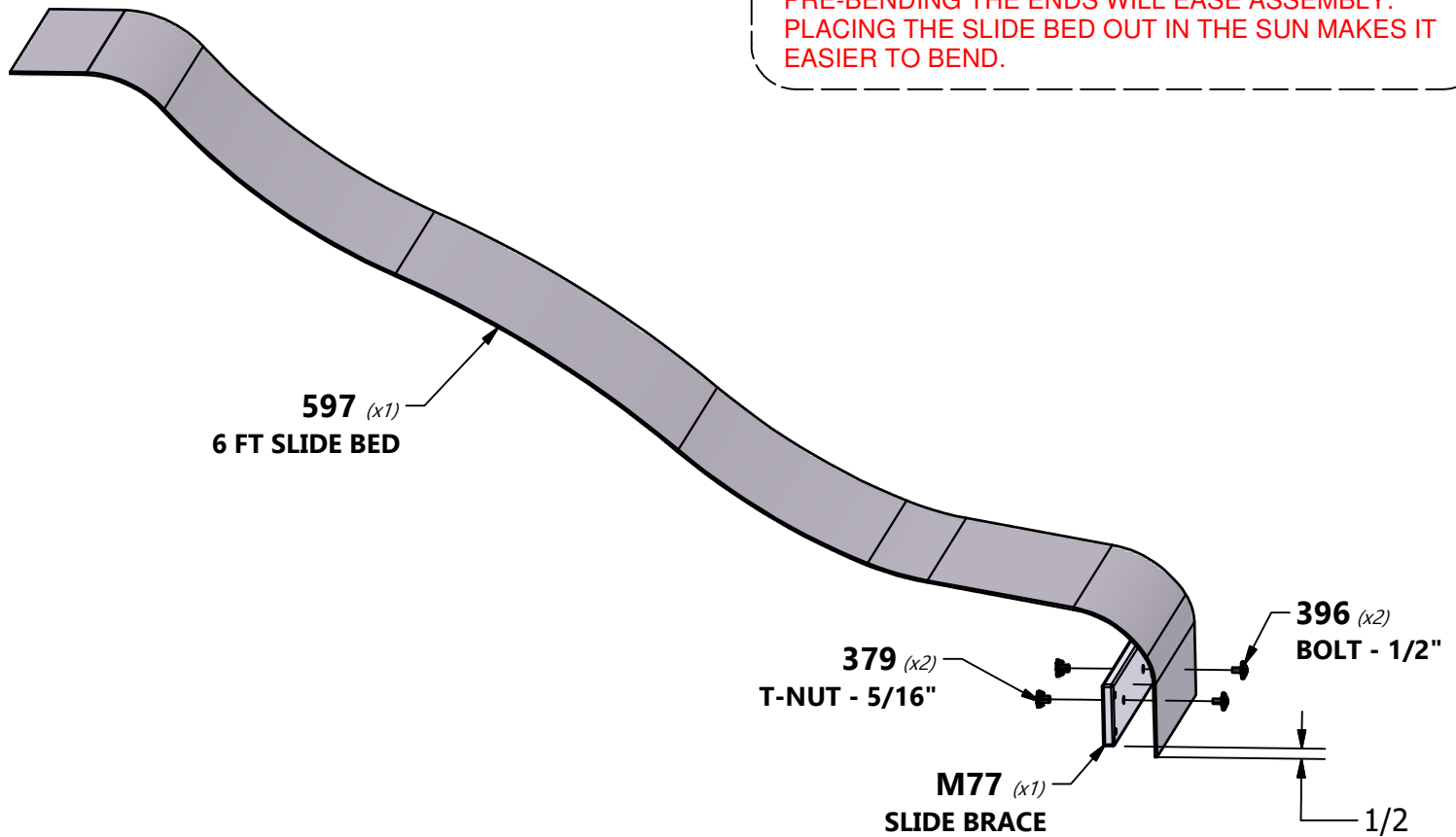

STEP 2 - SLIDE

QTY	PART NUMBER	DESCRIPTION
16	H100201	SCREW PFH 8x2 1/2 BLK



A6P00598
(x1) **6 FT SLIDE RAIL RIGHT**

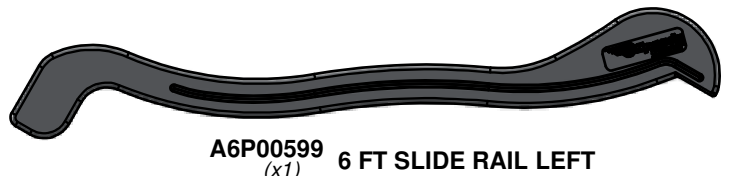

A6P00599
(x1) **6 FT SLIDE RAIL LEFT**

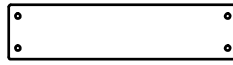

M78 SLIDE BRACE - W4L13298
(x1) 5/8"x3 3/8"x14 1/4" (16x86x362)

- NOTE:**
1. PLACE THE SLIDE RAIL ON FLAT SURFACE. STARTING AT THE BOTTOM, INSERT THE SLIDE BED INTO THE CHANNEL ON THE INSIDE OF THE RAIL. HOLD THE SLIDE BED IN PLACE WHILE A HELPER BENDS THE SLIDE BED INTO THE CHANNEL. MAKE SURE THE SLIDE BED IS COMPLETELY INSERTED INTO THE CHANNEL. **SEE VIEWING WINDOW BELOW.**
 2. INSERT THE CENTER SLIDE BRACE INTO THE RESPECTIVE LOCATION.
 3. USING A 1/8" DRILL BIT, DRILL PILOT HOLES IN EACH INDENTATION ALONG EACH SIDE RAIL. THERE SHOULD BE 8 INDENTATIONS ON EACH RAIL. BE SURE TO DRILL THROUGH THE SLIDE RAIL AND THE SLIDE BED. THEN SECURE WITH THE PROVIDED HARDWARE.
- REPEAT THIS PROCESS FOR THE OPPOSITE SLIDE RAIL.**

FAILURE TO INSERT SLIDE BED COMPLETELY AND SECURED BY SCREWS MAY RESULT IN INJURY OR AMPUTATION. EXPOSED SLIDE EDGES CAN BE SHARP AND BECOME A LACERATION HAZARD IF THE SLIDE IS NOT PROPERLY ASSEMBLED.

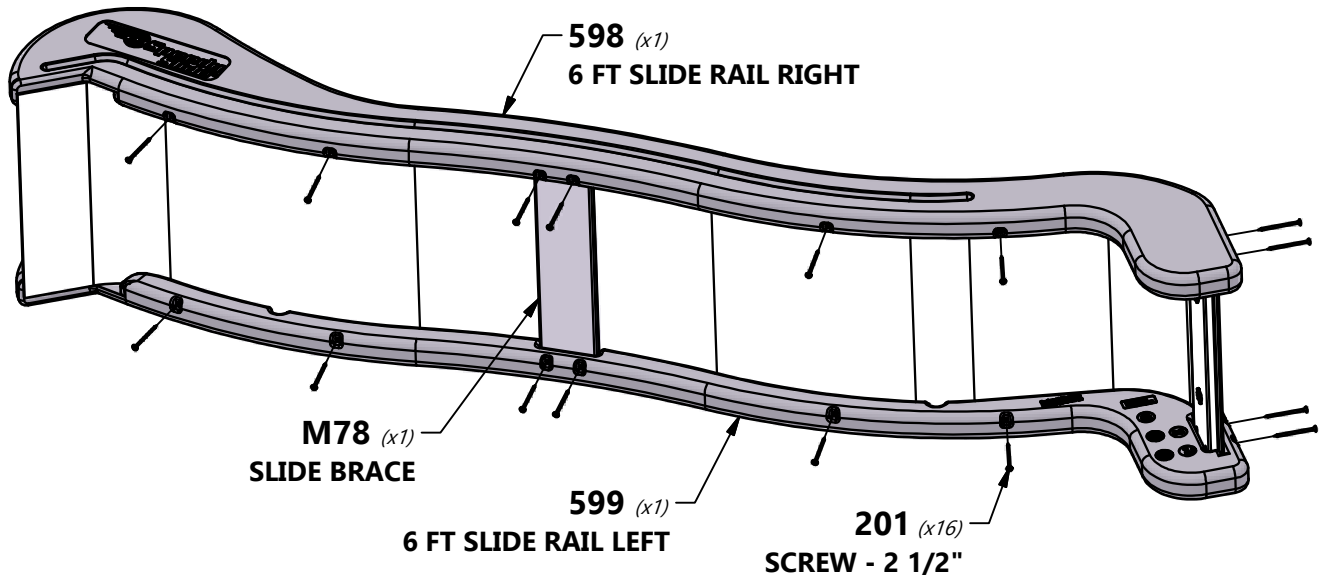

TIP:
A HELPER IS REQUIRED FOR THIS STEP.

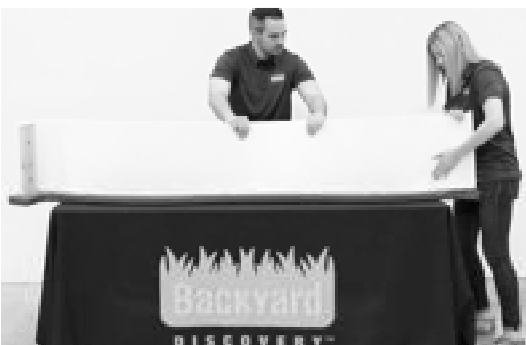

STEP 1 - DECK ASSEMBLY

QTY	PART NUMBER	DESCRIPTION
6	H100198	WASHER LOCK EXT 8x19 BLK
5	H100205	BOLT WH 5/16x2-1/4 BLK
6	H100379	T-NUT 5/16 BLK
1	H100483	SCREW PFH 8x2 1/4 BLK
1	H100484	BOLT WH 5/16x3 1/4 BLK

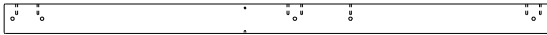

E1 LEFT FRONT UPRIGHT - W4L17837
(x1) 1 3/8"x3 3/8"x62 3/8" (36x86x1584)



E4 LEFT REAR UPRIGHT - W4L17840
(x1) 1 3/8"x3 3/8"x35" (36x86x889)



H2 FLOOR RAIL - W4L17846
(x1) 1"x3 3/8"x54 7/8" (24x86x1394)

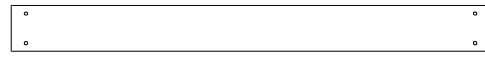

G2 GROUND BOARD - W4L17842
(x1) 1"x5 1/4"x54 7/8" (24x134x1394)



J1 FLOOR SUPPORT BLOCK - W4L17858
(x1) 1"x3 3/8"x3 3/8" (24x86x86)

TIP:
WE RECOMMEND THAT YOU INSTALL ALL "T-NUTS" FIRST, WHEN A "T-NUT" IS REQUIRED, THROUGHOUT THE ASSEMBLY PROCESS.

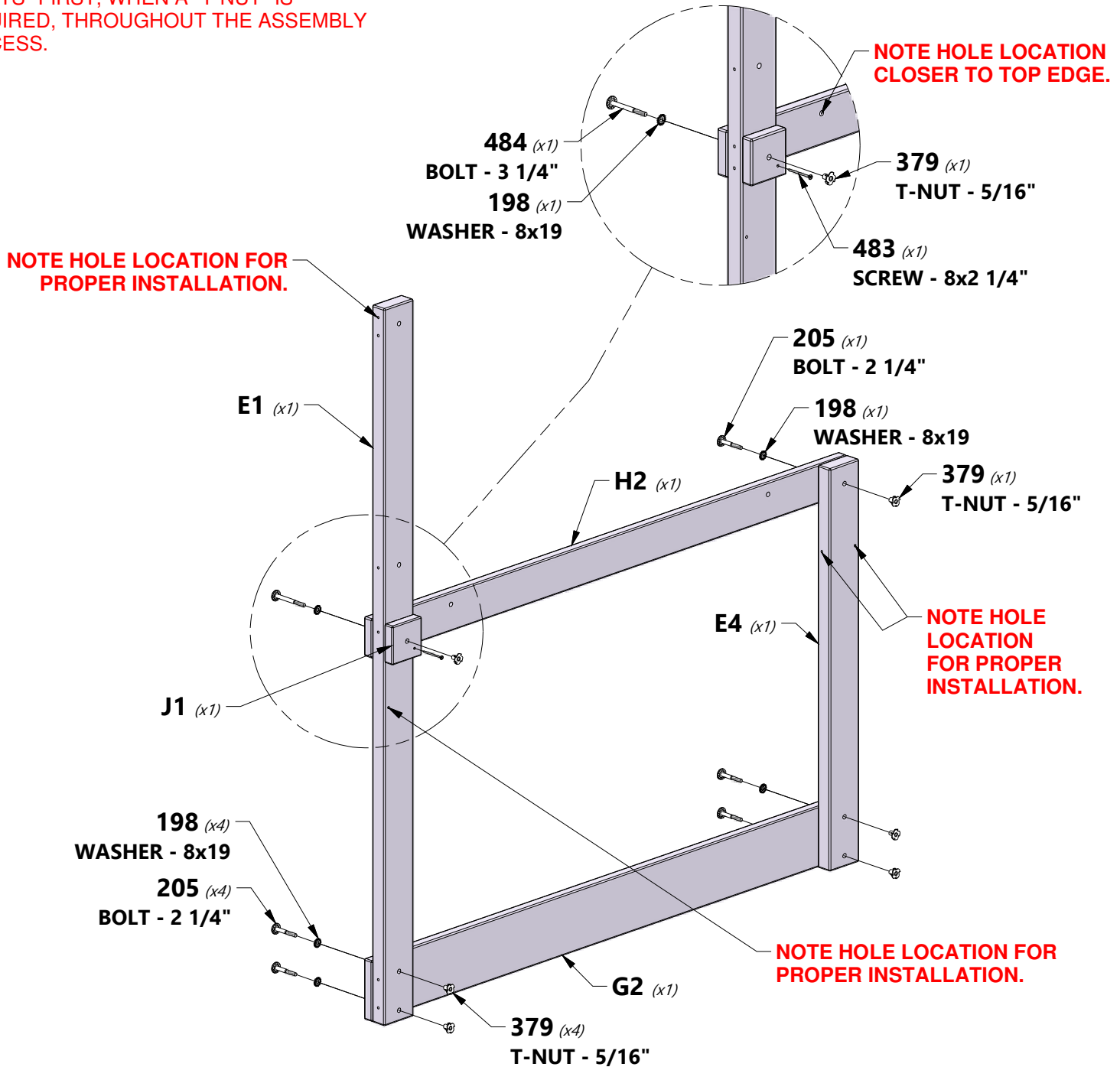

STEP 2 - DECK ASSEMBLY



QTY	PART NUMBER	DESCRIPTION
4	H100198	WASHER LOCK EXT 8x19 BLK
4	H100458	LAG SCREW WH 5/16x2 BLK

G1 GROUND BOARD - W4L17841
(x2) 1"x5 1/4"x56 3/4" (24x134x1442)

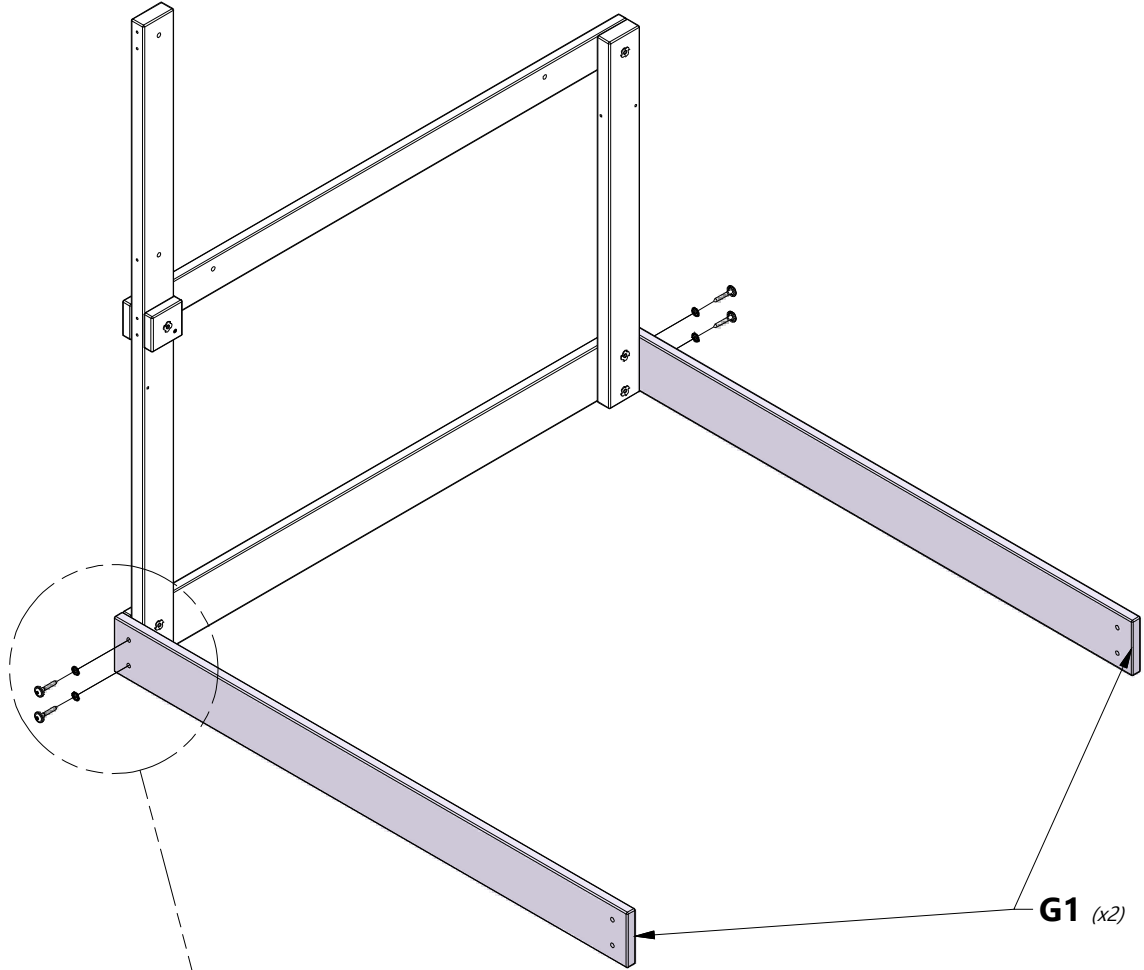

198 (x4)
WASHER - 8x19

458 (x4)
LAG SCREW - 2"

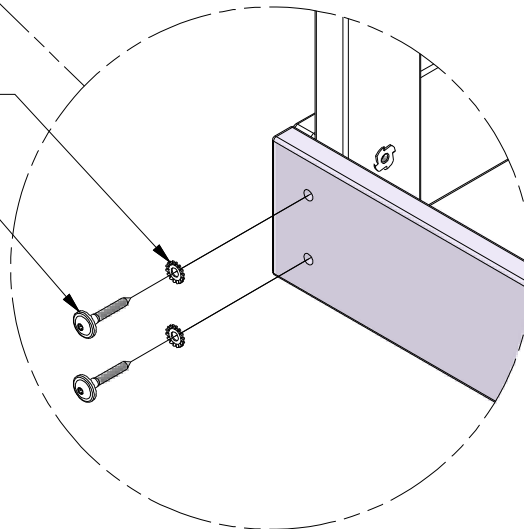

STEP 3 - DECK ASSEMBLY

QTY	PART NUMBER	DESCRIPTION
6	H100198	WASHER LOCK EXT 8x19 BLK
4	H100205	BOLT WH 5/16x2-1/4 BLK
8	H100379	T-NUT 5/16 BLK
2	H100483	SCREW PFH 8x2 1/4 BLK
2	H100484	BOLT WH 5/16x3 1/4 BLK



E2 RIGHT FRONT UPRIGHT - W2A03762
(x1) 1 3/8"x3 3/8"x62 3/8" (36x86x1584)



E3 RIGHT REAR UPRIGHT - W4L17839
(x1) 1 3/8"x3 3/8"x62 3/8" (36x86x1584)

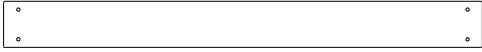

G2 GROUND BOARD - W4L17842
(x1) 1"x5 1/4"x54 7/8" (24x134x1394)



H4 FLOOR RAIL - W4L17847
(x1) 1"x3 3/8"x54 7/8" (24x86x1394)



J1 FLOOR SUPPORT BLOCK - W4L17858
(x2) 1"x3 3/8"x3 3/8" (24x86x86)

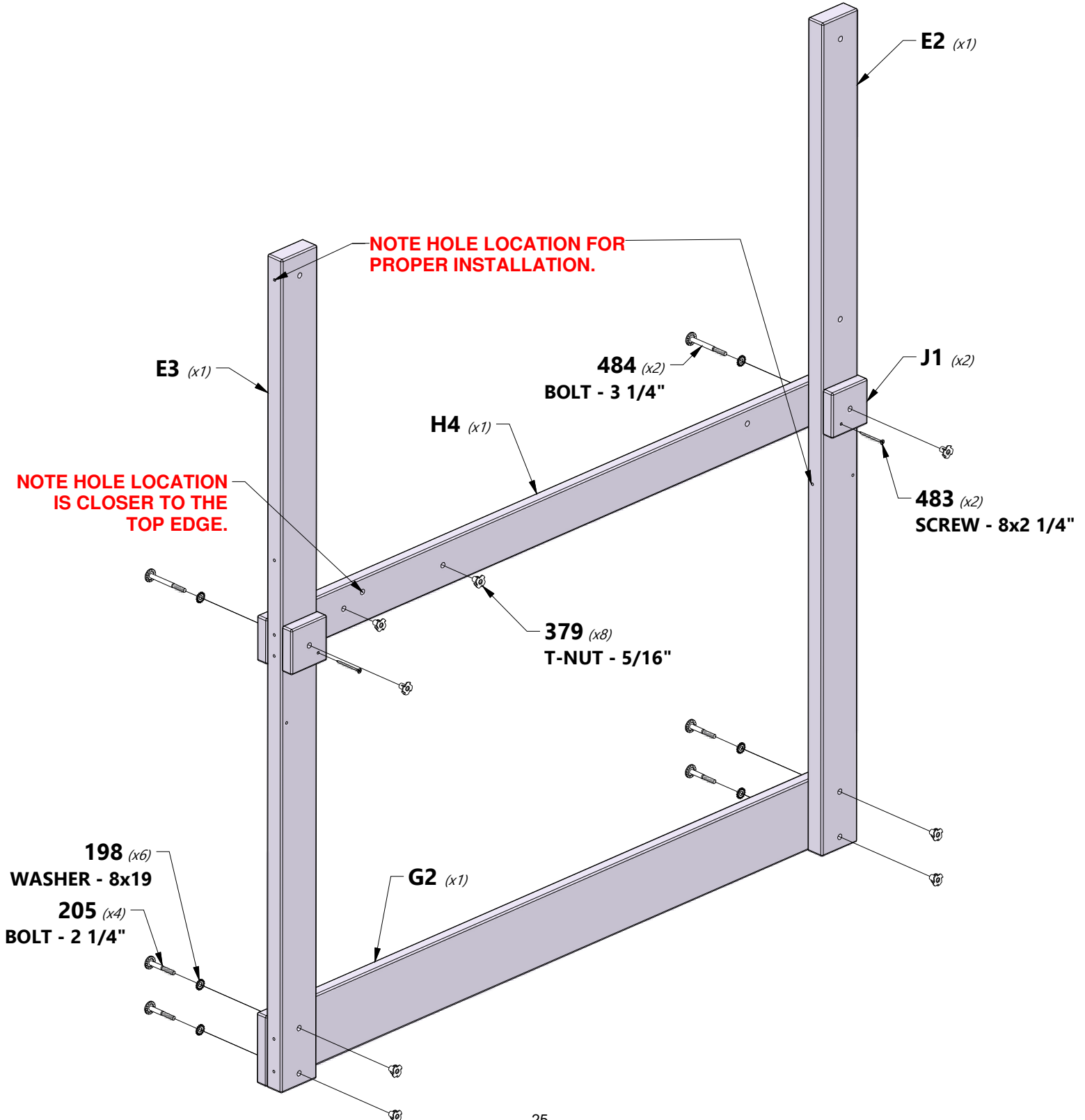

STEP 4 - DECK ASSEMBLY

QTY	PART NUMBER	DESCRIPTION
4	H100198	WASHER LOCK EXT 8x19 BLK
4	H100458	LAG SCREW WH 5/16x2 BLK

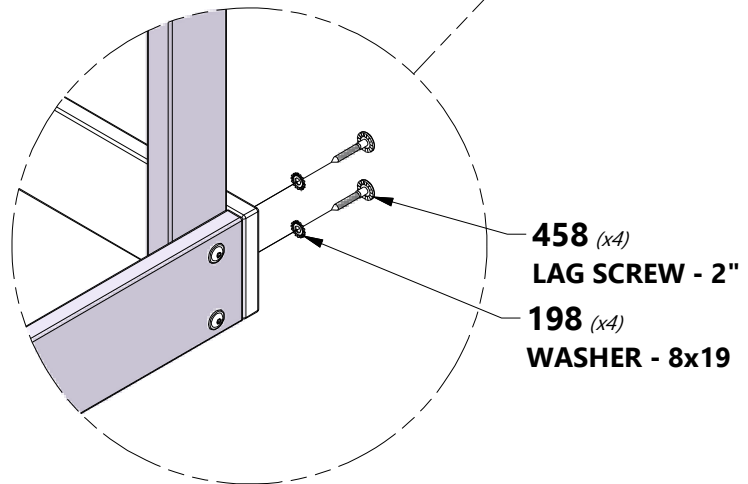
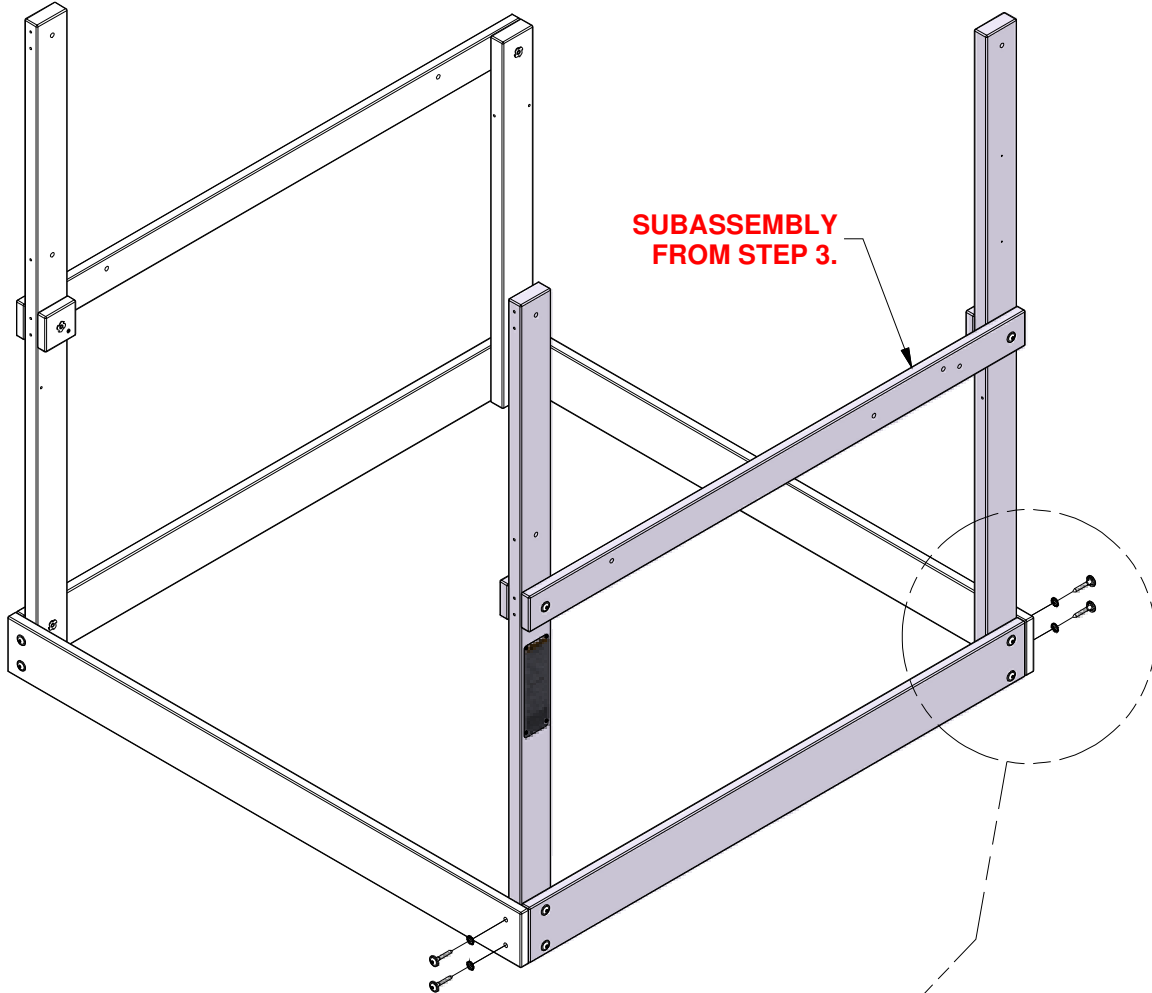

STEP 5 - DECK ASSEMBLY

QTY	PART NUMBER	DESCRIPTION
4	H100198	WASHER LOCK EXT 8x19 BLK
4	H100458	LAG SCREW WH 5/16x2 BLK



H1 FLOOR RAIL - W4L17845
(x1) 1"x3 3/8"x56 3/4" (24x86x1442)

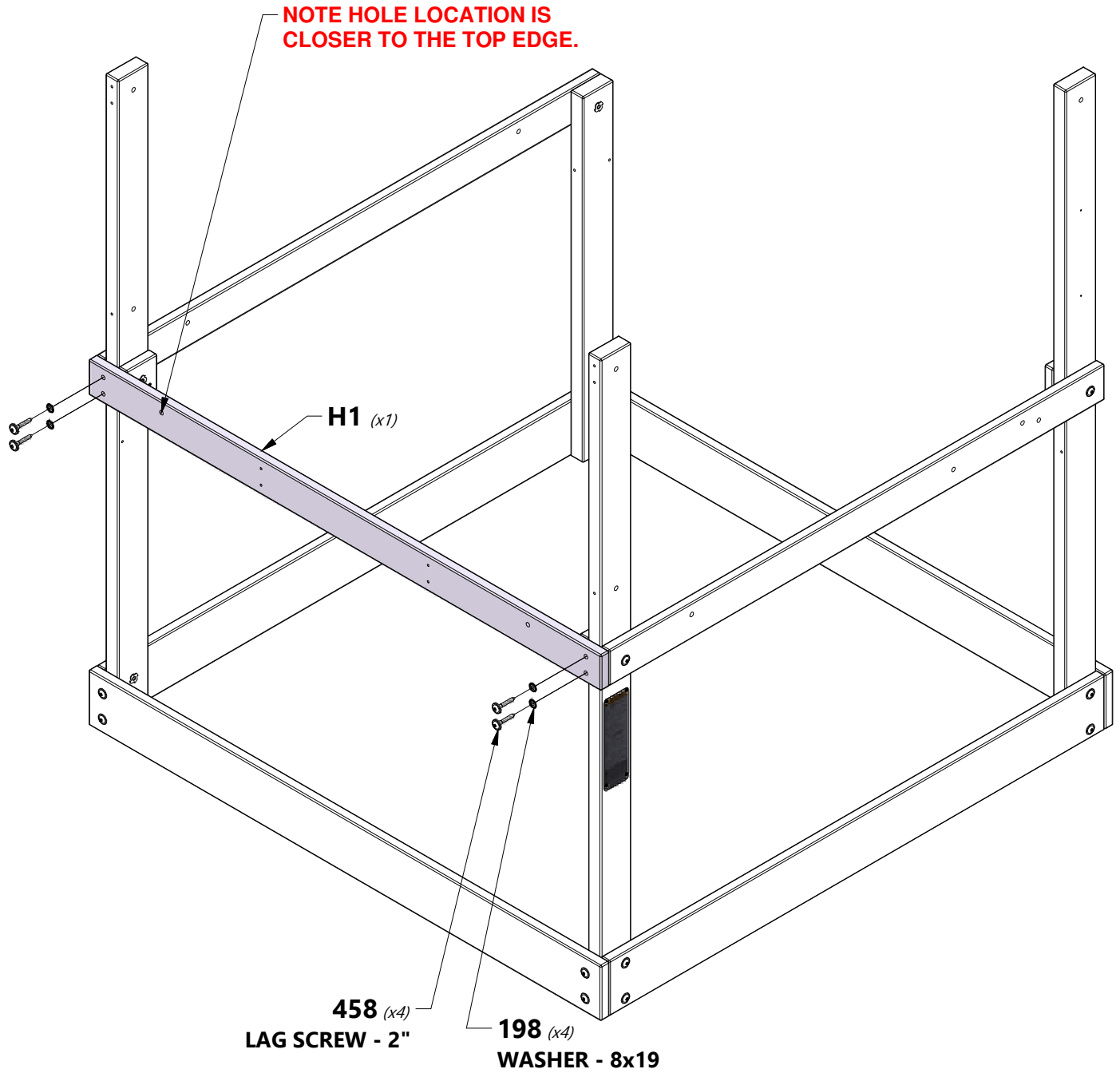

STEP 6 - DECK ASSEMBLY

QTY	PART NUMBER	DESCRIPTION
4	H100198	WASHER LOCK EXT 8x19 BLK
4	H100458	LAG SCREW WH 5/16x2 BLK

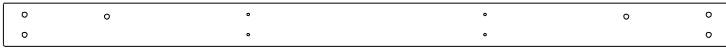

H1 FLOOR RAIL - W4L17845
(x1) 1"x3 3/8"x56 3/4" (24x86x1442)

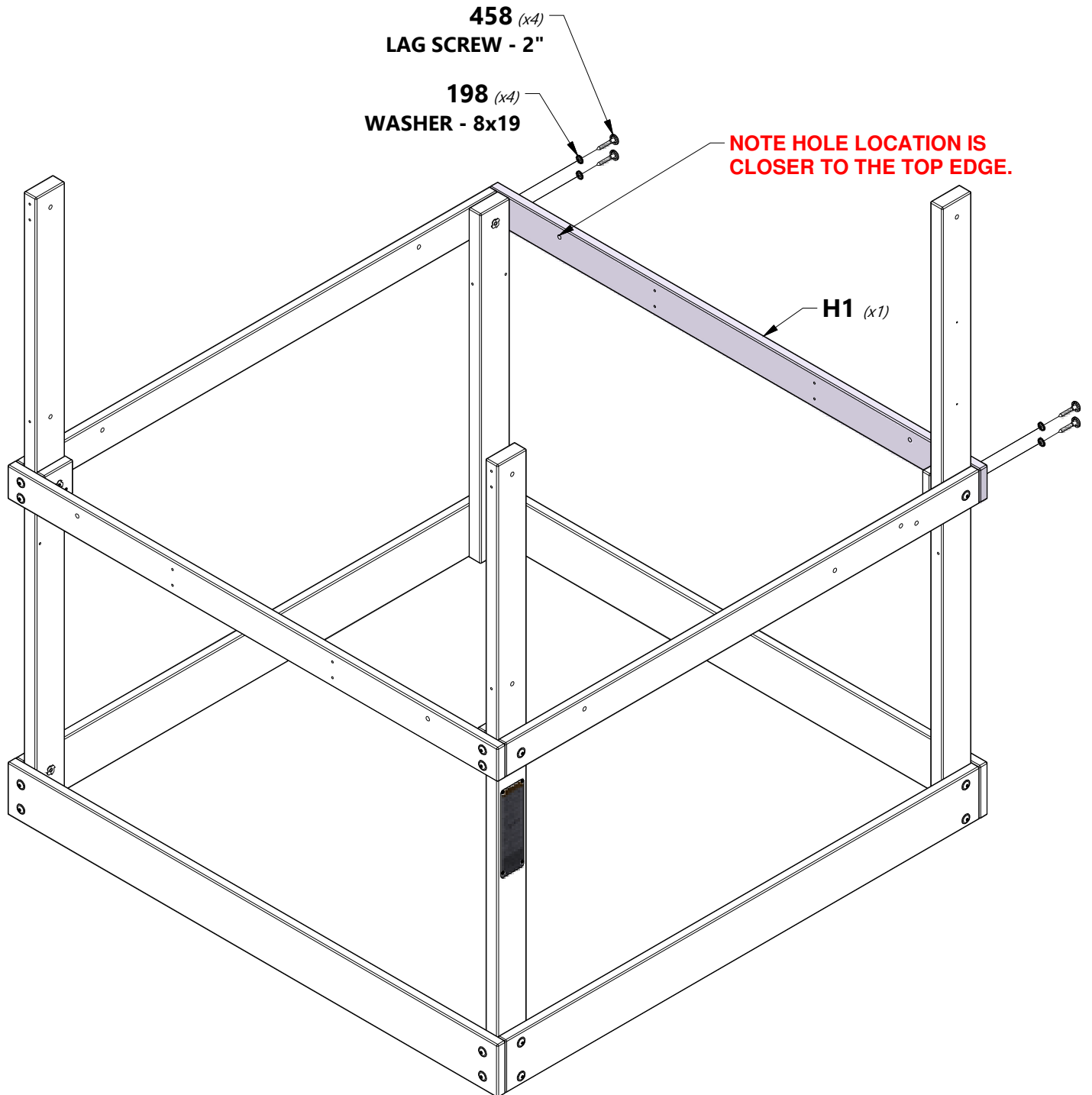

STEP 7 - DECK ASSEMBLY



H20 DECK BRACE - W4L17854
(x8) 1"x3 3/8"x13" (24x86x330)

QTY	PART NUMBER	DESCRIPTION
8	H100198	WASHER LOCK EXT 8x19 BLK
8	H100378	BOLT WH 5/16x1 3/4 BLK
8	H100379	T-NUT 5/16 BLK
8	H100403	LAG SCREW WH 1/4x1-1/2 BLK
8	H100405	WASHER LOCK EXT 6x15 BLK

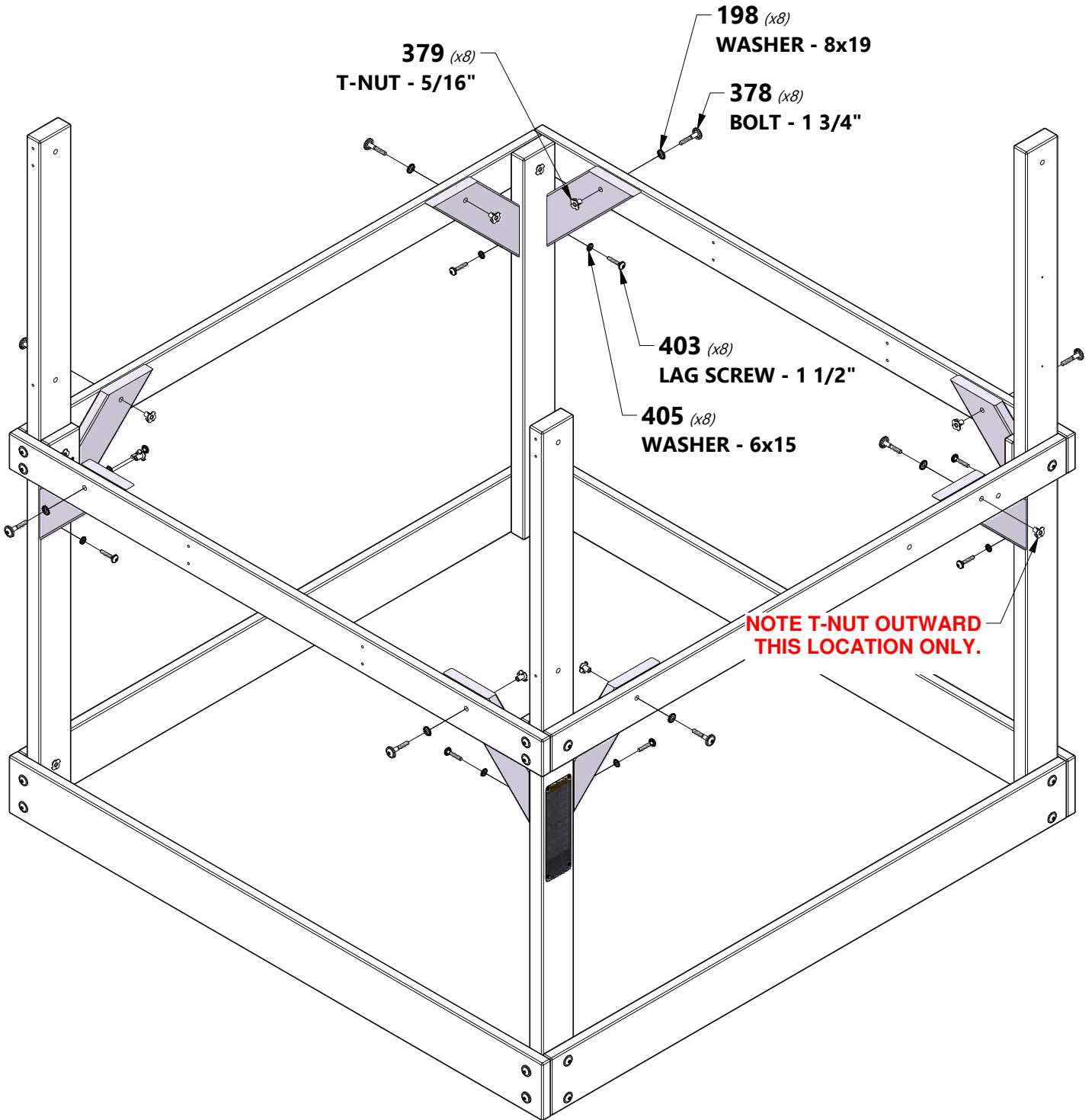

STEP 8 - DECK ASSEMBLY

QTY	PART NUMBER	DESCRIPTION
8	H100201	SCREW PFH 8x2-1/2 BLK



H5 FLOOR SUPPORT - W4L17848
(x2) 1"x3 3/8"x54 7/8" (24x86x1394)

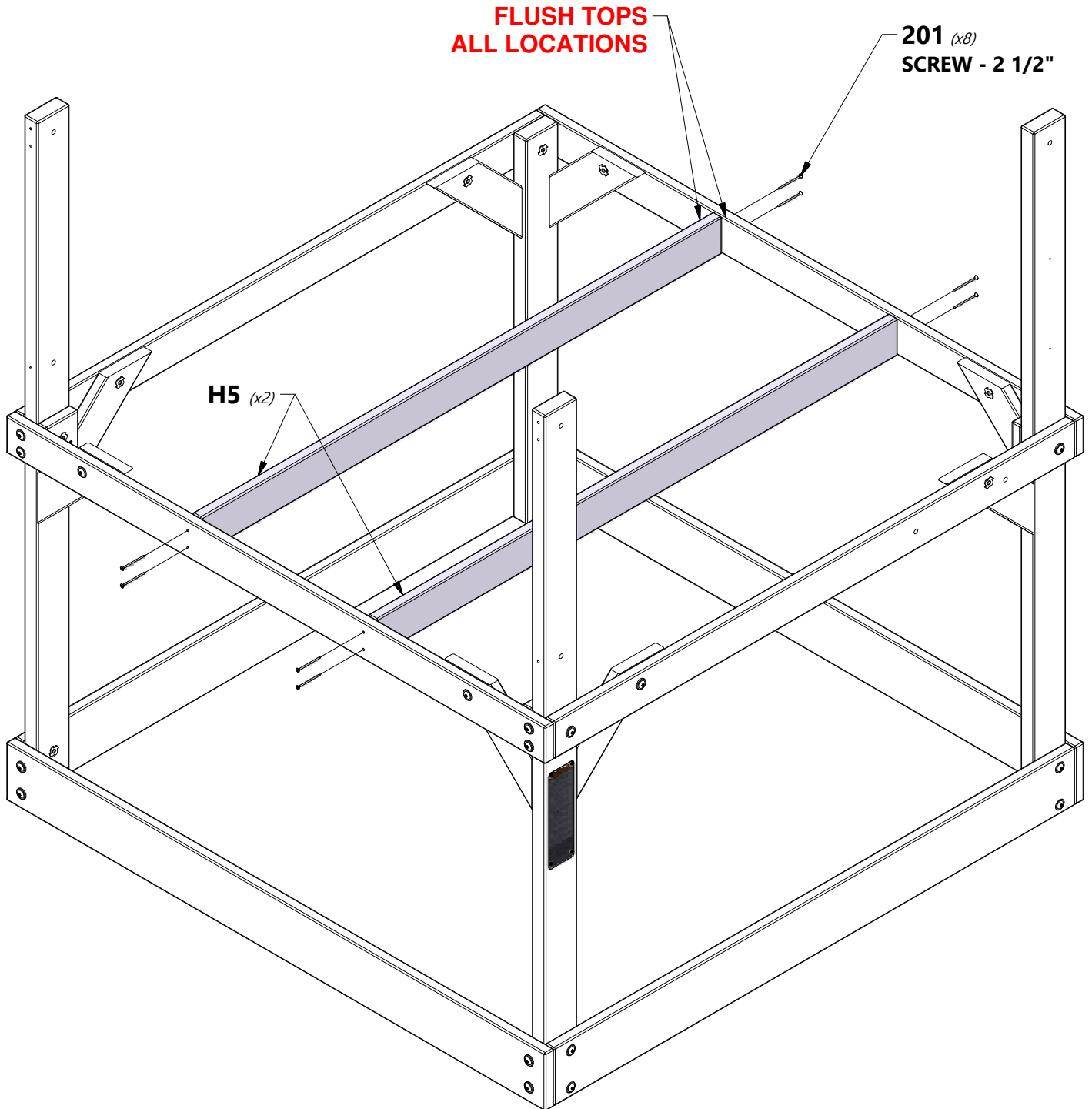

STEP 9 - DECK ASSEMBLY

QTY	PART NUMBER	DESCRIPTION
96	H100200	SCREW PFH 8x1-1/2 BLK



L1 FLOOR BOARD - W4L17860
(x1) 5/8"x4 3/8"x52" (16x112x1321)

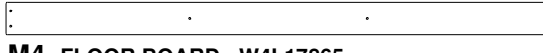

M4 FLOOR BOARD - W4L17865
(x13) 5/8"x3 3/8"x56 3/4" (16x86x1442)



L2 FLOOR BOARD - W4L17861
(x1) 5/8"x4 3/8"x54 3/8" (16x112x1382)

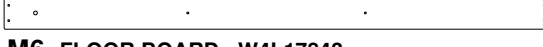

M6 FLOOR BOARD - W4L17843
(x1) 5/8"x3 3/8"x56 3/4" (16x86x1442)

NOTE:
ALL FLOOR BOARDS SHOULD BE SPACED EVENLY.

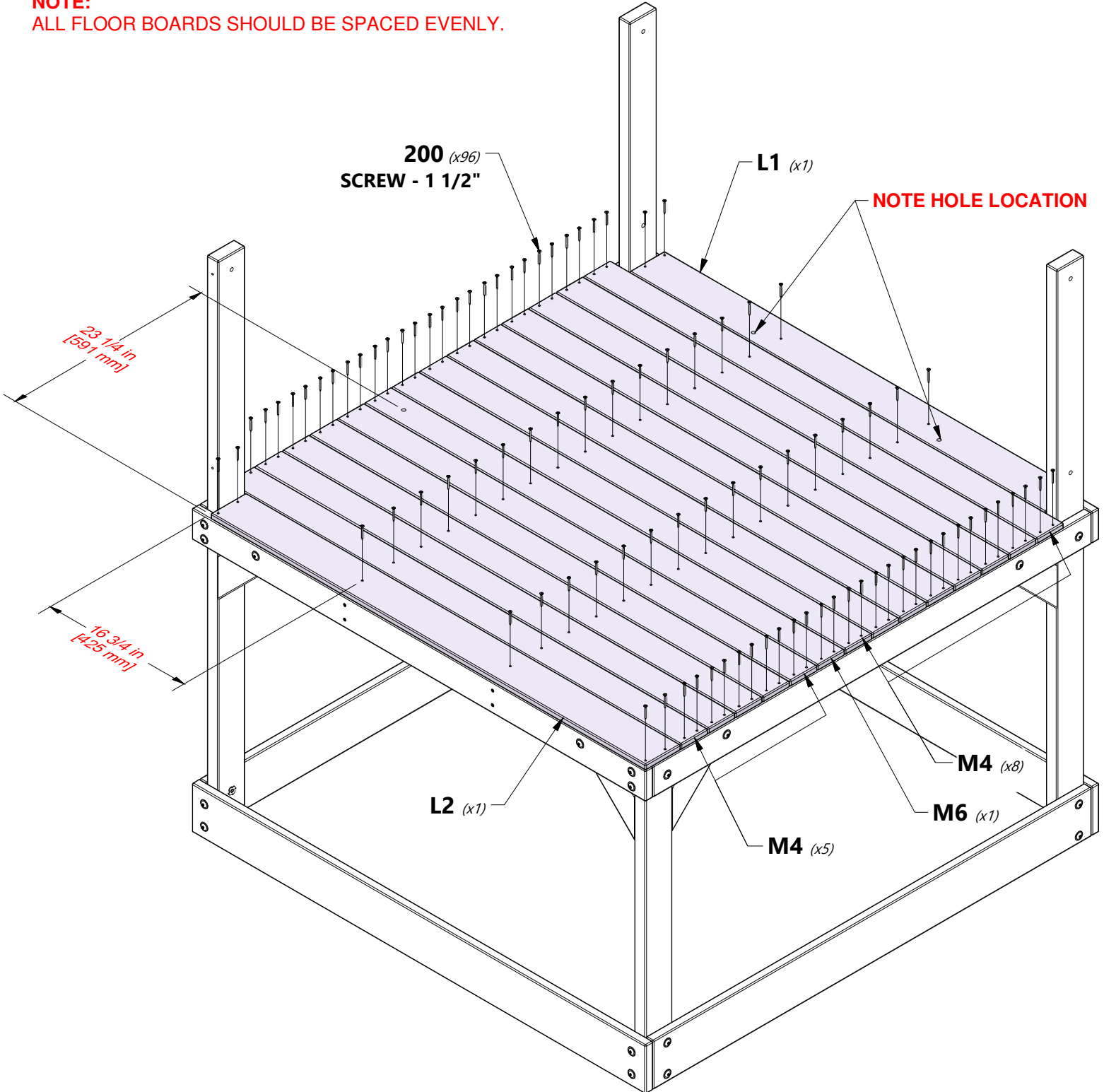

STEP 10 - DECK ASSEMBLY



H6 WALL RAIL - W4L17849
(x2) 1"x3 3/8"x18 1/2" (24x86x469)

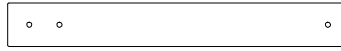

M7 WALL BOARD - W4L17844
(x2) 5/8"x3 3/8"x26 1/2" (16x86x673)



A4M01047 L BRACKET
(x2) 2.5x38x55x55

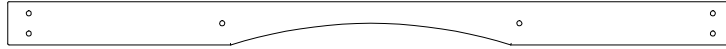

H7 WALL RAIL - W4L17850
(x1) 1"x3 3/8"x56 3/4" (24x86x1442)

QTY	PART NUMBER	DESCRIPTION
10	H100198	WASHER LOCK EXT 8x19 BLK
2	H100199	WASHER LOCK EXT 12x19 BLK
6	H100379	T-NUT 5/16 BLK
4	H100396	BOLT WH 5/16x1/2 BLK
6	H100458	LAG SCREW WH 5/16x2 BLK
2	H100469	NUT BARREL WH 5/16x5/8 BLK
4	H100407	BOLT WH 5/16x1 1/2 BLK

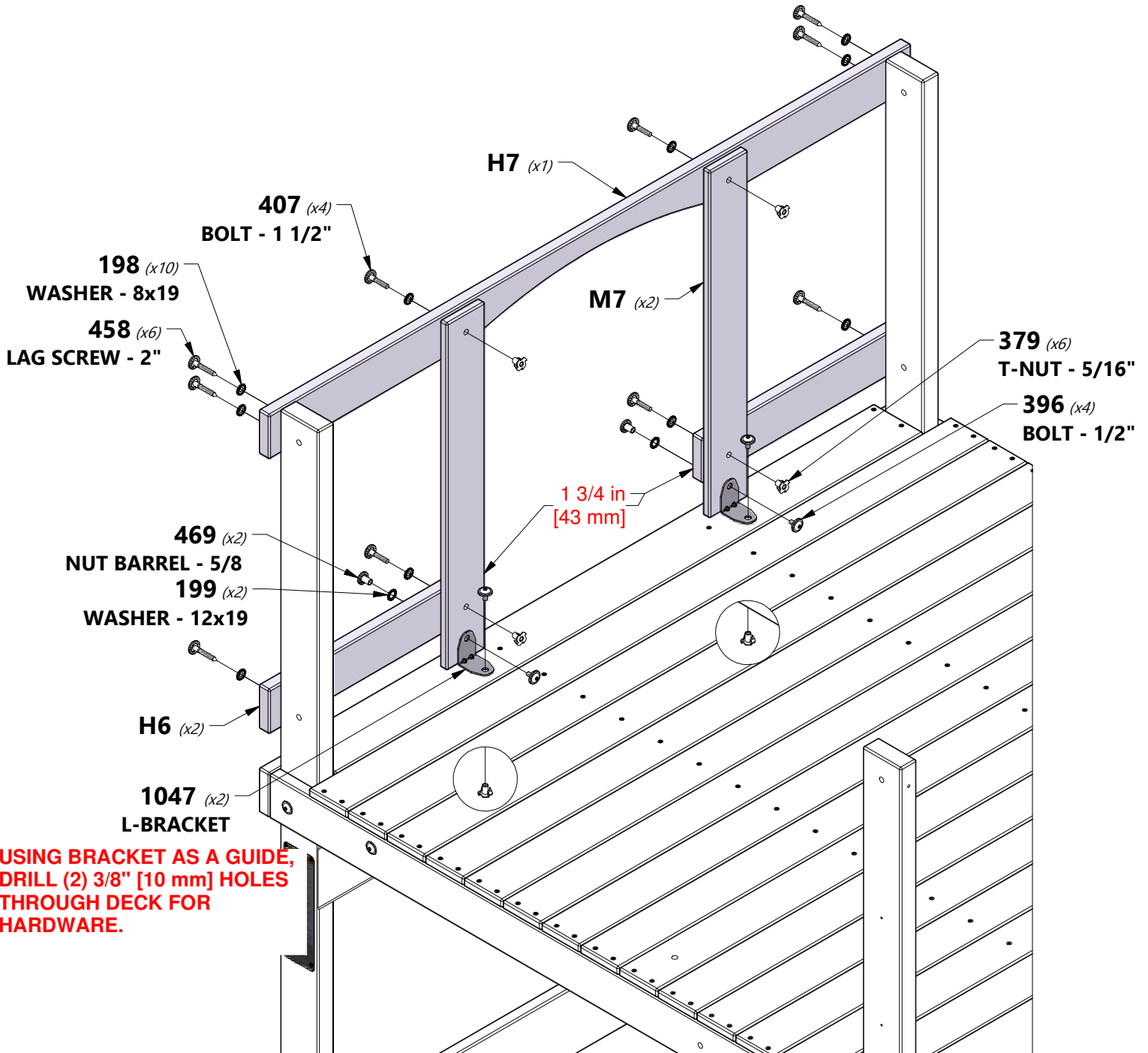

STEP 11 - DECK ASSEMBLY



H8 WALL RAIL - W4L17851
 (x1) 1"x3 3/8"x34 1/4" (24x86x871)

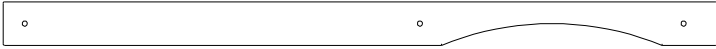

H11 WALL RAIL - W4L17877
 (x1) 1"x3 3/8"x55 7/8" (24x86x1418)

QTY	PART NUMBER	DESCRIPTION
3	H100198	WASHER LOCK EXT 8x19 BLK
3	H100205	BOLT WH 5/16x2-1/4 BLK
3	H100379	T-NUT 5/16 BLK

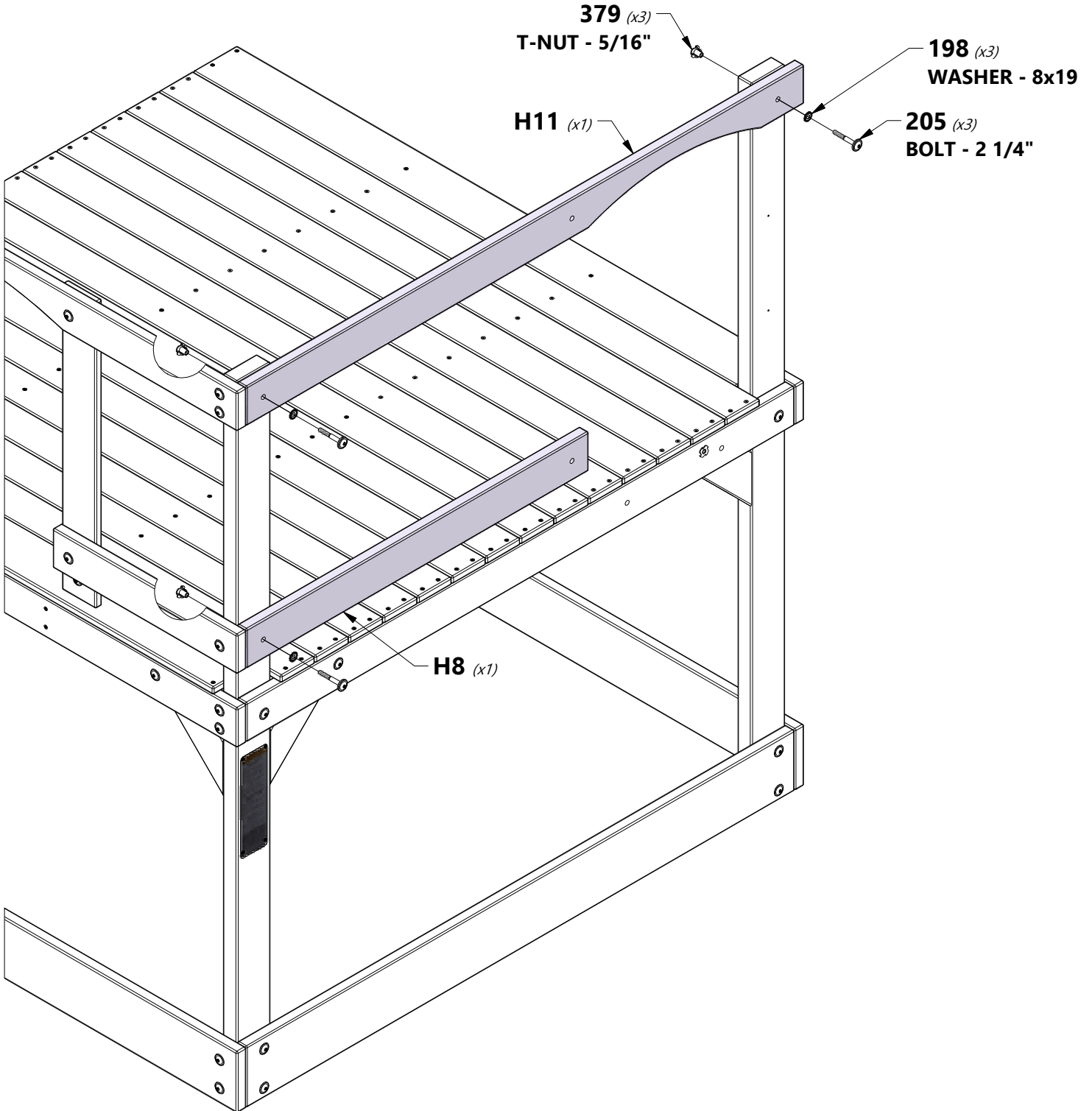

STEP 12 - DECK ASSEMBLY

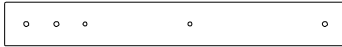

M10 WALL BOARD - W4L17866
(x1) 5/8"x3 3/8"x26 1/2" (16x86x673)



A4M01047 L BRACKET
(x1) 2.5x38x55x55

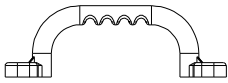

A6P00654 HAND GRIP
(x2) GREY PLASTIC

QTY	PART NUMBER	DESCRIPTION
2	H100171	BOLT WH 1/4x1 BLK
2	H100198	WASHER LOCK EXT 8x19 BLK
1	H100199	WASHER LOCK EXT 12x19 BLK
3	H100379	T-NUT 5/16 BLK
2	H100396	BOLT WH 5/16x1/2 BLK
2	H100398	T-NUT 1/4 BLK
2	H100403	LAG SCREW WH 1/4x1-1/2 BLK
4	H100405	WASHER LOCK EXT 6x15 BLK
2	H100407	BOLT WH 5/16x1 1/2 BLK
1	H100469	NUT BARREL WH 5/16x5/8 BLK

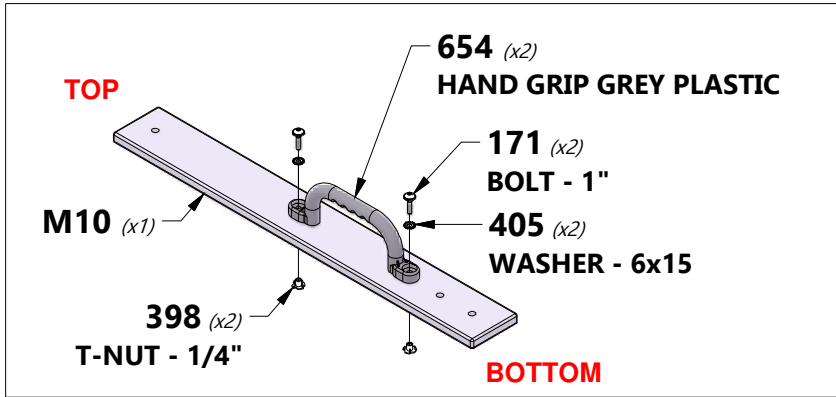

NOTE:
ASSEMBLE HAND GRIP TO 'M10' BOARD FIRST.

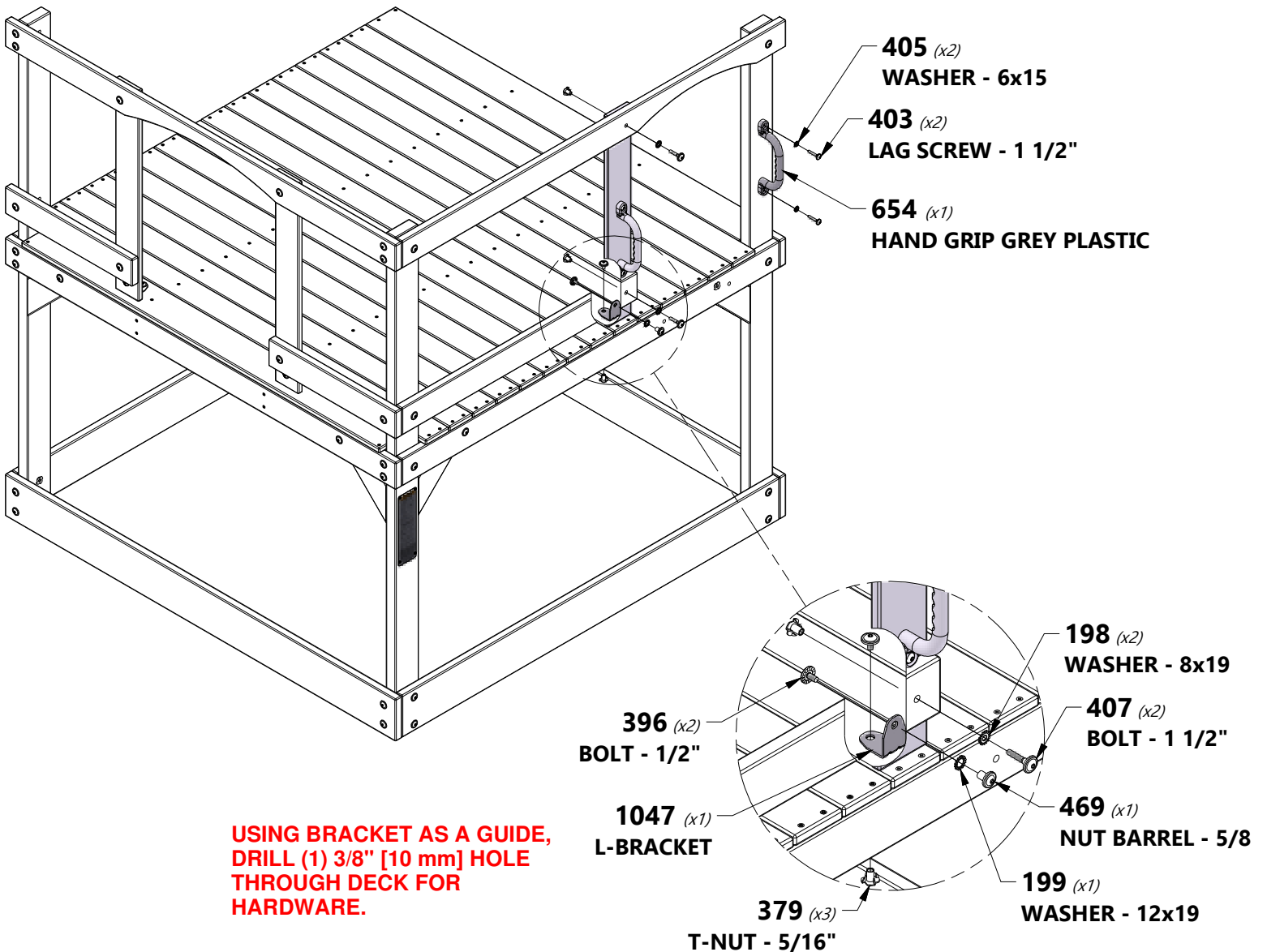

USING BRACKET AS A GUIDE, DRILL (1) 3/8" [10 mm] HOLE THROUGH DECK FOR HARDWARE.

STEP 13 - DECK ASSEMBLY



H9 WALL RAIL - W4L17852
(x2) 1"x3 3/8"x16 5/8" (24x86x423)

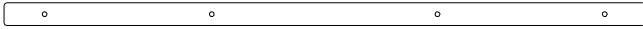

S1 RAIL BOARD - W4L17874
(x1) 1"x1"x26 3/4" (24x24x679)

QTY	PART NUMBER	DESCRIPTION
2	H100198	WASHER LOCK EXT 8x19 BLK
4	H100200	SCREW PFH 8x1-1/2 BLK
2	H100205	BOLT WH 5/16x2-1/4 BLK
2	H100379	T-NUT 5/16 BLK

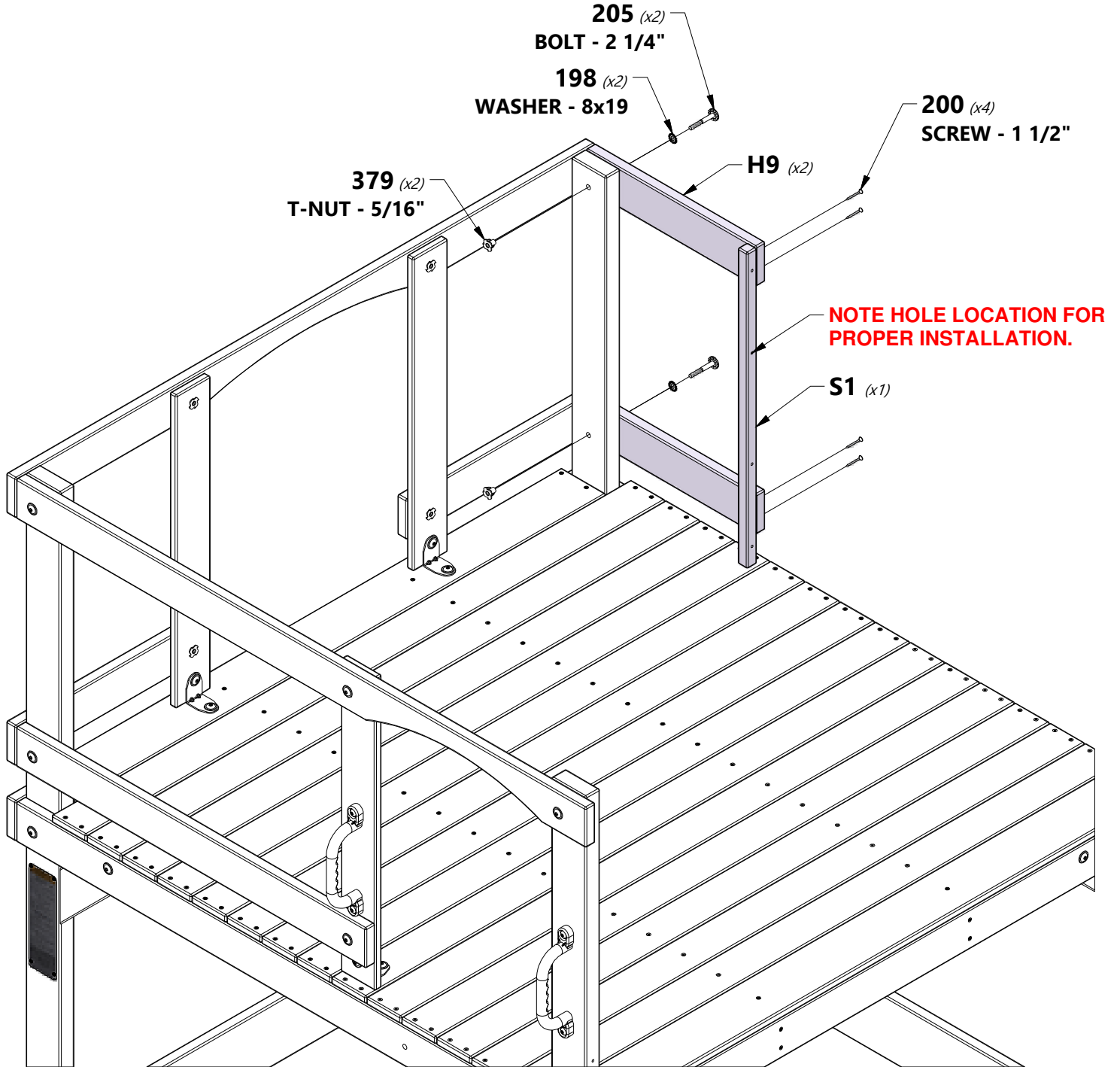

STEP 14 - DECK ASSEMBLY



H10 WALL RAIL - W4L17853
(x2) 1"x3 3/8"x16 3/4" (24x86x426)

QTY	PART NUMBER	DESCRIPTION
2	H100198	WASHER LOCK EXT 8x19 BLK
4	H100200	SCREW PFH 8x1-1/2 BLK
2	H100458	LAG SCREW WH 5/16x2 BLK



S1 RAIL BOARD - W4L17874
(x1) 1"x1"x26 3/4" (24x24x679)

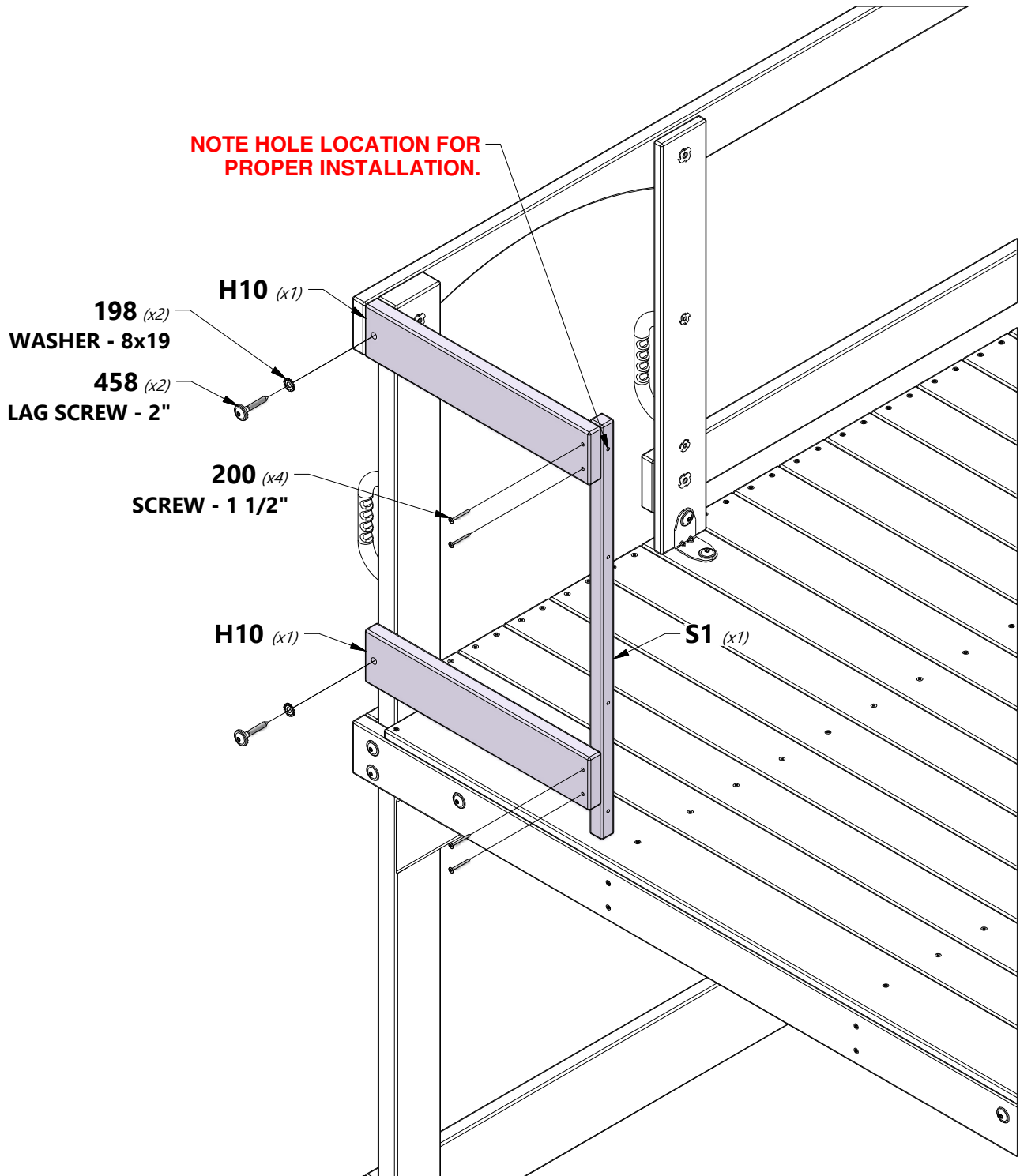

STEP 15 - DECK ASSEMBLY

QTY	PART NUMBER	DESCRIPTION
6	H100380	SCREW PFH 8x1 1/8 BLK



O1 PICKET - W4L17872
(x3) 5/8"x1 3/8"x20 1/2" (16x34x520)

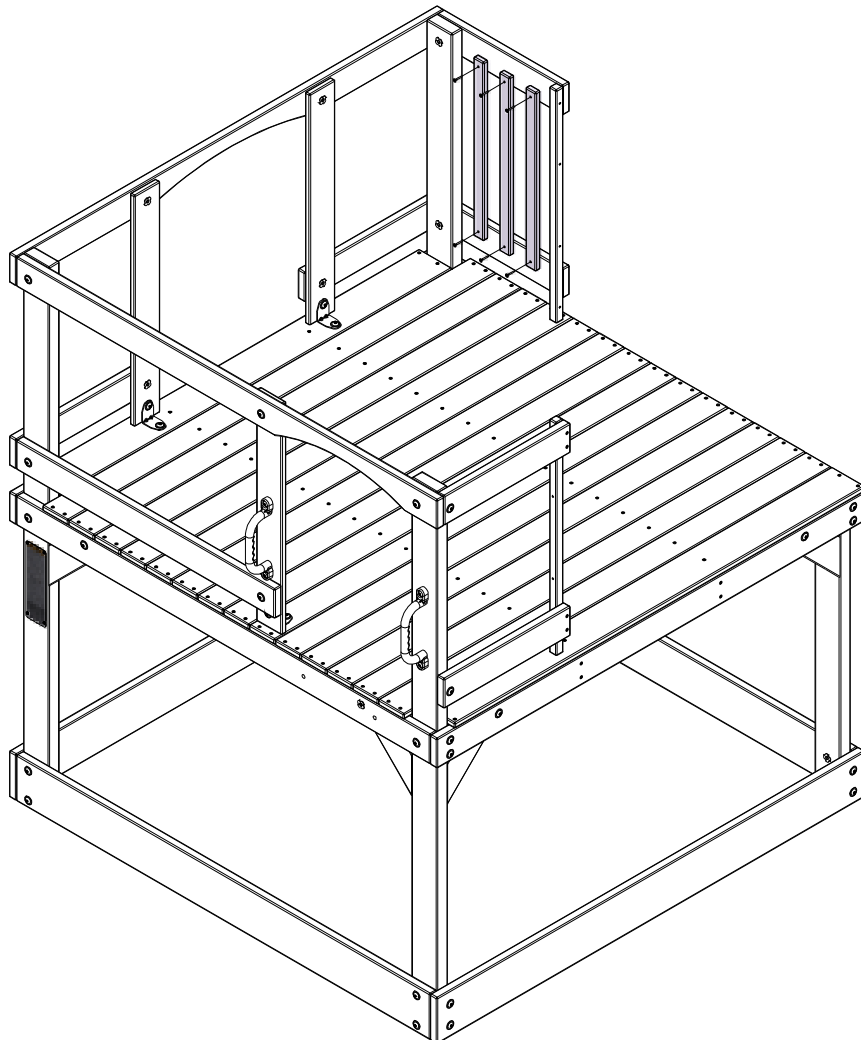
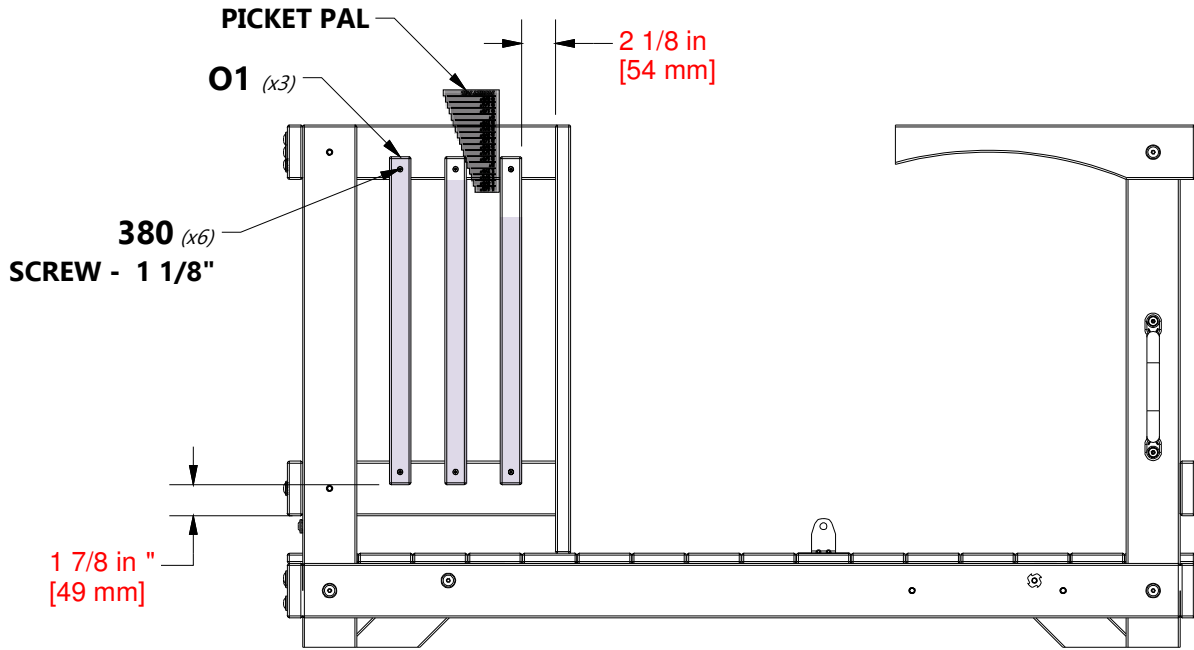

STEP 16 - DECK ASSEMBLY

QTY	PART NUMBER	DESCRIPTION
12	H100380	SCREW PFH 8x1 1/8 BLK



O1 PICKET - W4L17872
(x6) 5/8"x1 3/8"x20 1/2" (16x34x520)

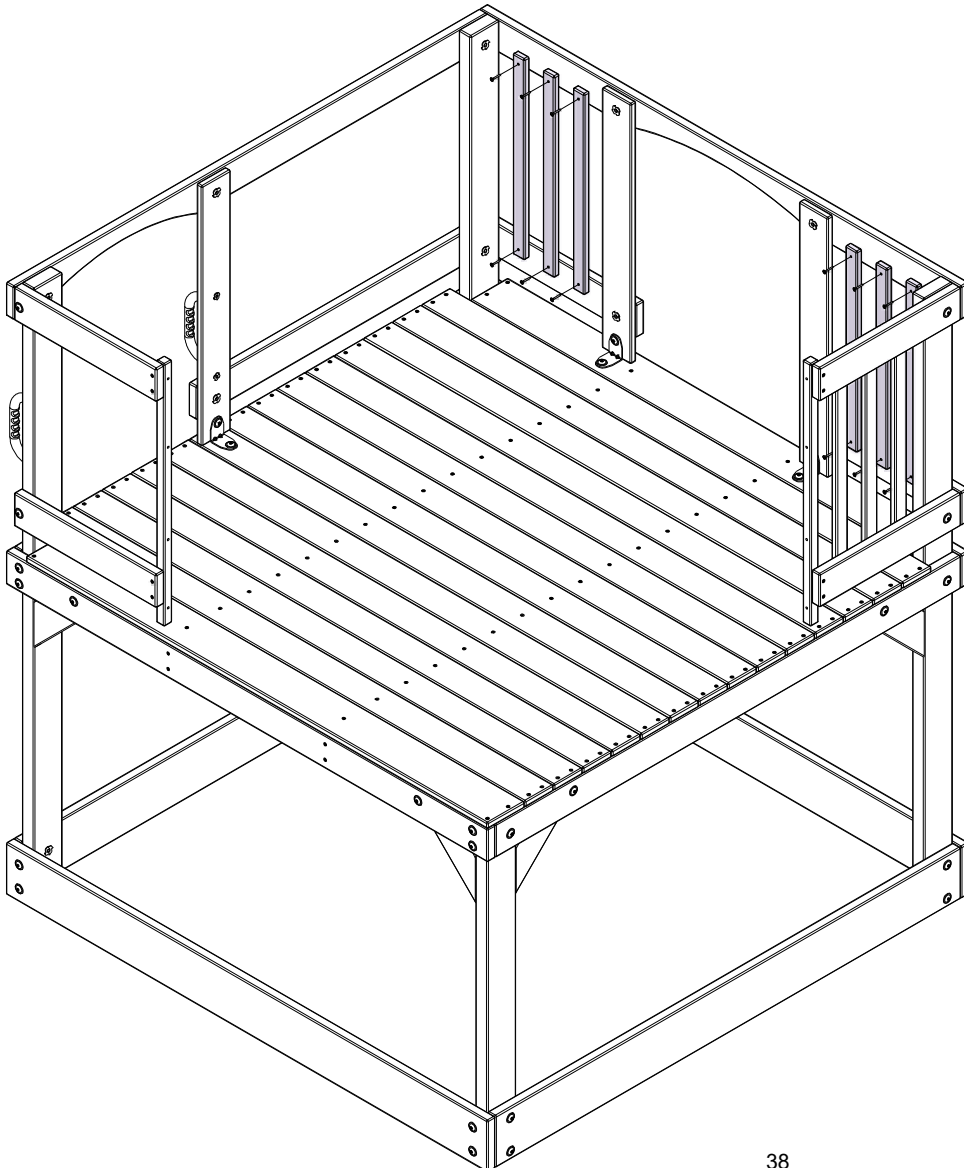
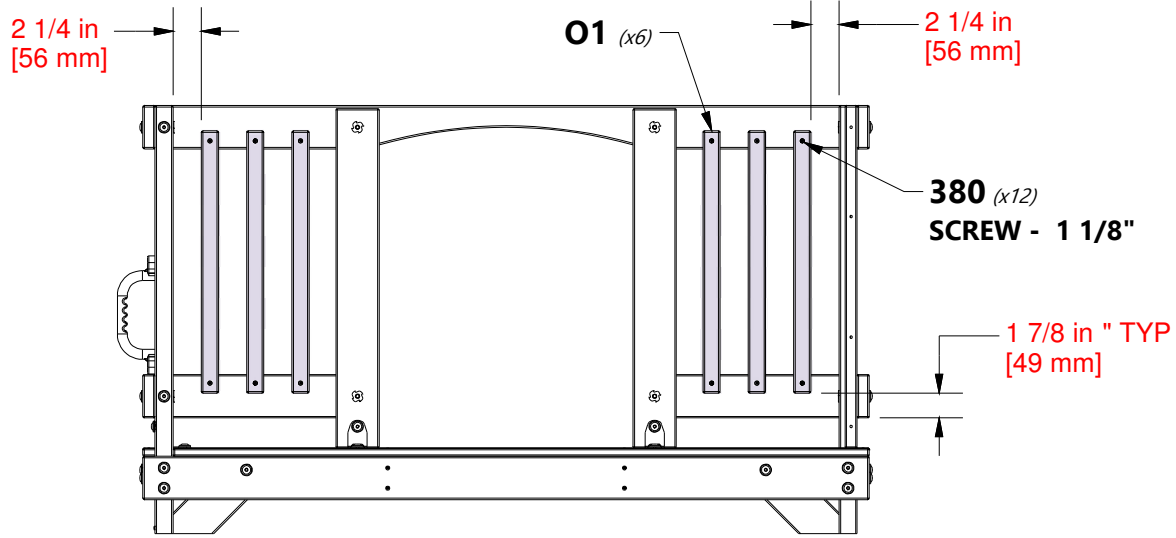

STEP 17 - DECK ASSEMBLY

QTY	PART NUMBER	DESCRIPTION
14	H100380	SCREW PFH 8x1 1/8 BLK

O1 PICKET - W4L17872
(x7) 5/8"x1 3/8"x20 1/2" (16x34x520)

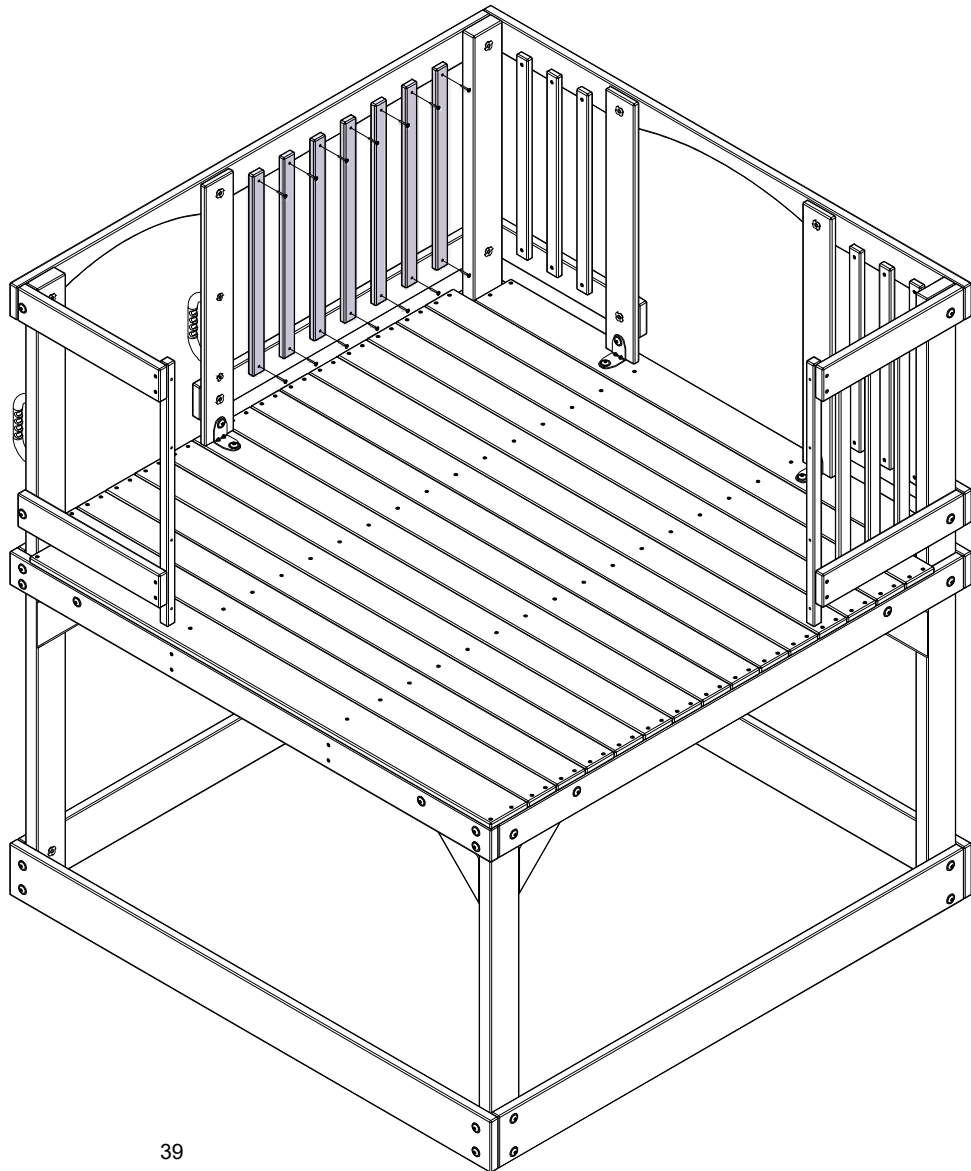
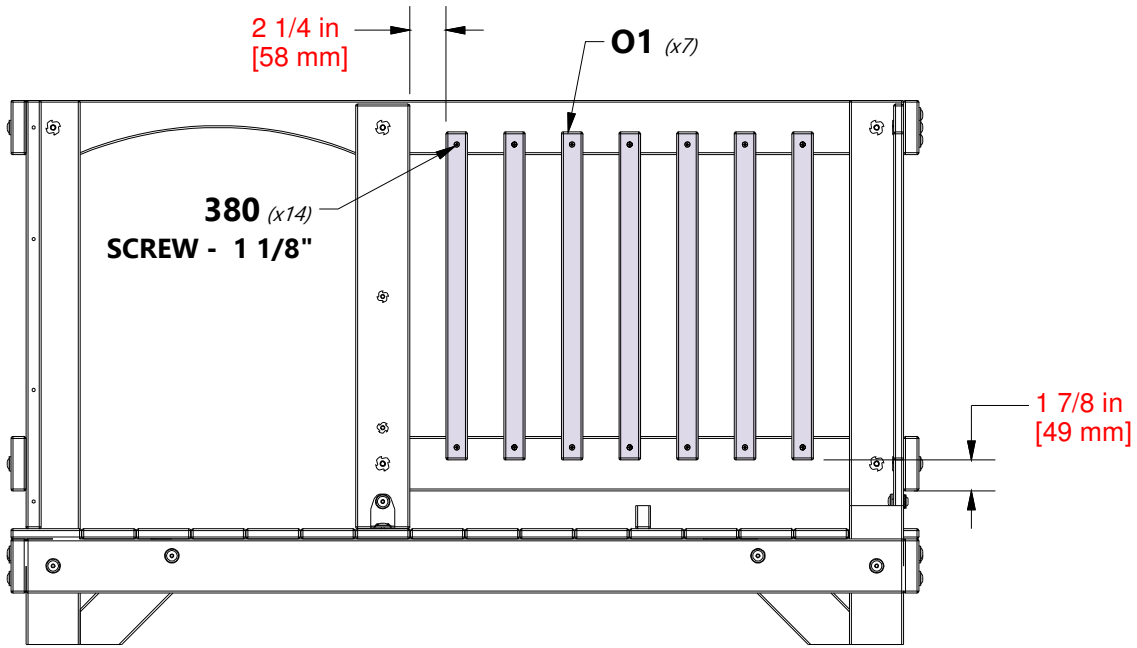

STEP 18 - DECK ASSEMBLY

QTY	PART NUMBER	DESCRIPTION
6	H100380	SCREW PFH 8x1 1/8 BLK



O1 PICKET - W4L17872
(x3) 5/8"x1 3/8"x20 1/2" (16x34x520)

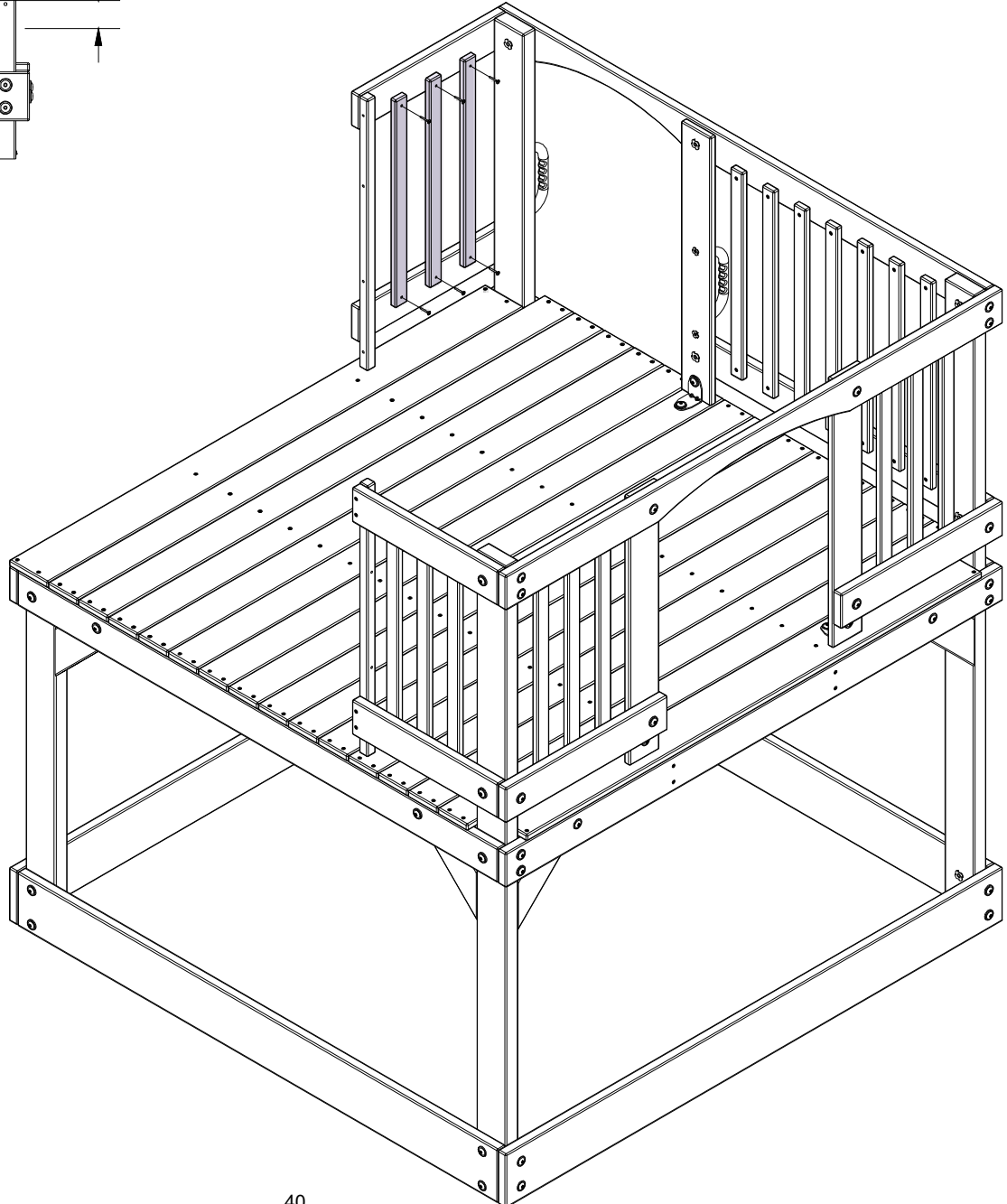
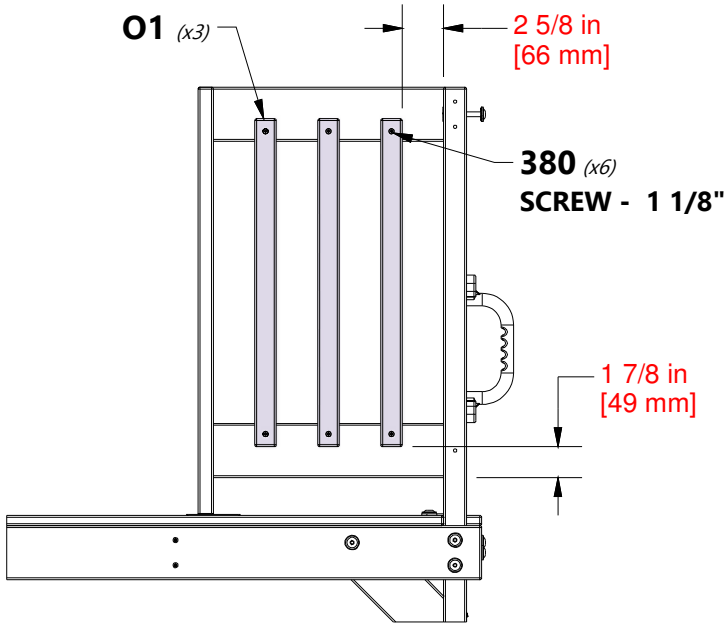

STEP 1 - PLAYHOUSE ASSEMBLY

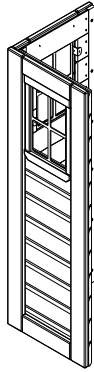

WP1 FRONT RIGHT CORNER PANEL - W2A03848
(x1)

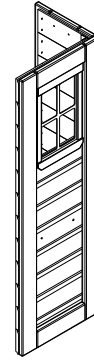

WP2 REAR RIGHT CORNER PANEL - W2A03851
(x1)

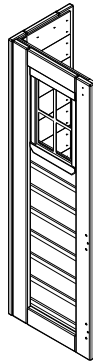

WP3 FRONT LEFT CORNER PANEL - W2A03854
(x1)

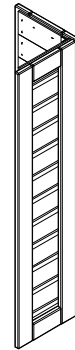

WP4 REAR LEFT CORNER PANEL - W2A03857
(x1)

NOTE:
STAND THE (4) CORNER WALL
ASSEMBLIES AS SHOWN
BELOW.

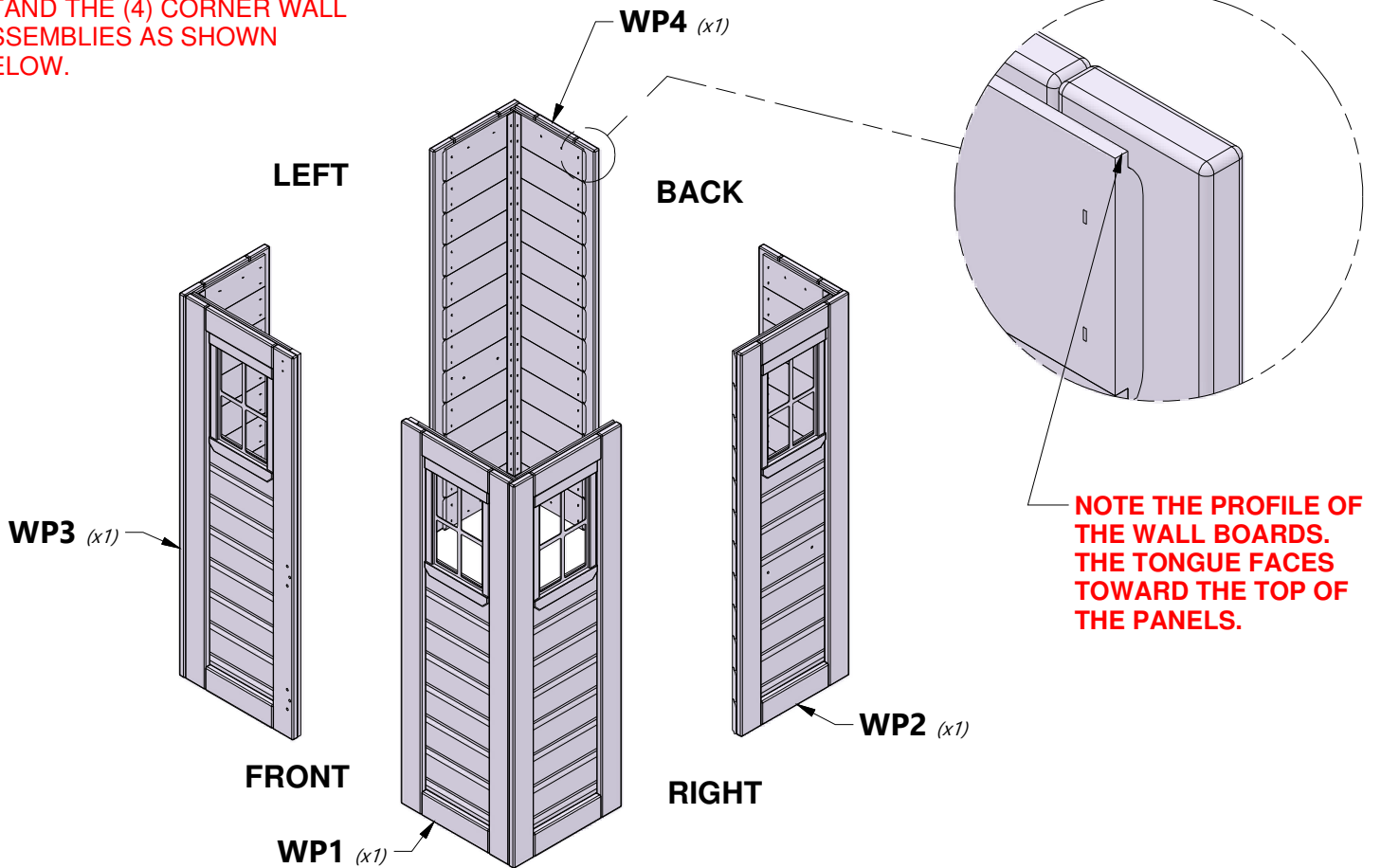

STEP 2 - PLAYHOUSE ASSEMBLY

QTY	PART NUMBER	DESCRIPTION
12	H100385	SCREW PFH 8x1 BLK



WP6 LEFT CENTER PANEL - W2A03861
 (x1) 1 1/4"x18 7/8"x20 7/8" (32x478x536)

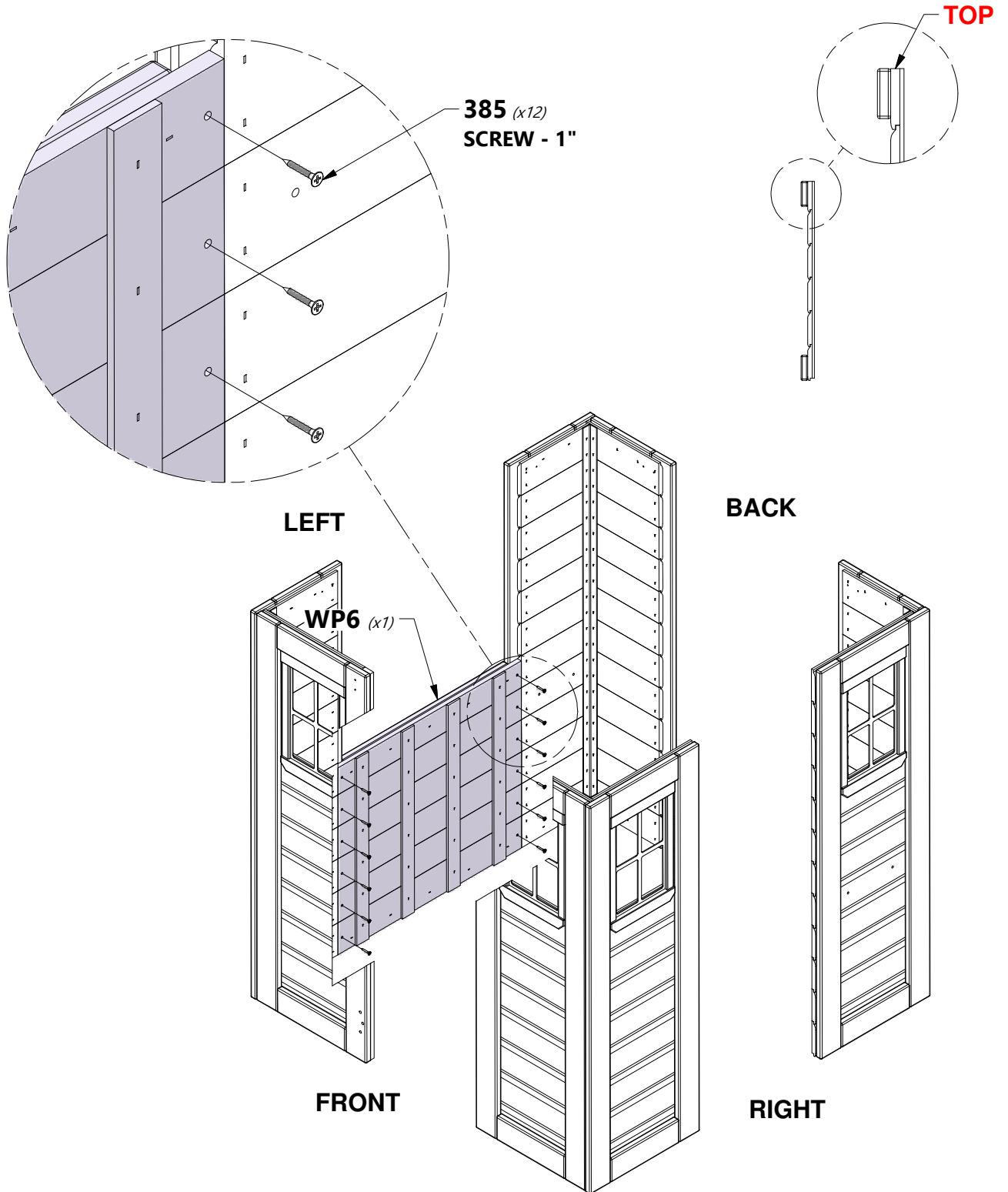

STEP 3 - PLAYHOUSE ASSEMBLY

QTY	PART NUMBER	DESCRIPTION
12	H100385	SCREW PFH 8x1 BLK

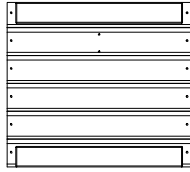

WP5 REAR CENTER PANEL - W2A03860
(x1) 1 1/4"x18 7/8"x20 7/8" (32x478x536)

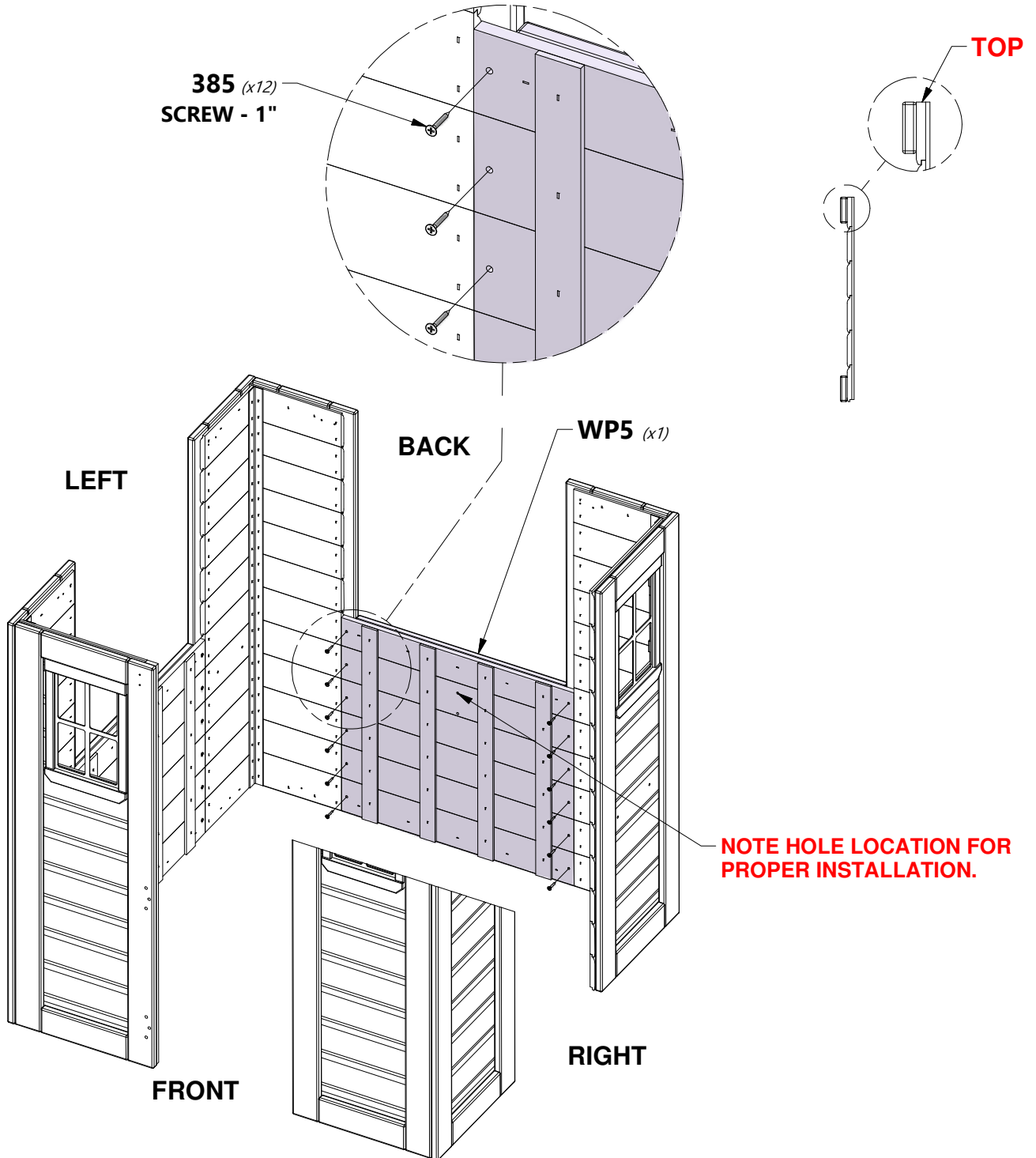

STEP 4 - PLAYHOUSE ASSEMBLY

QTY	PART NUMBER	DESCRIPTION
4	H100201	SCREW PFH 8x2 1/2 BLK

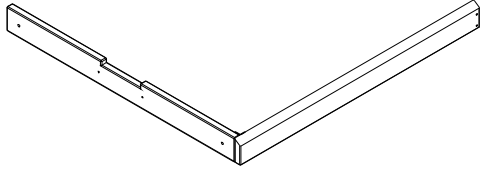

WP8 HEADER ASSEMBLY - W2A03862
(x2)

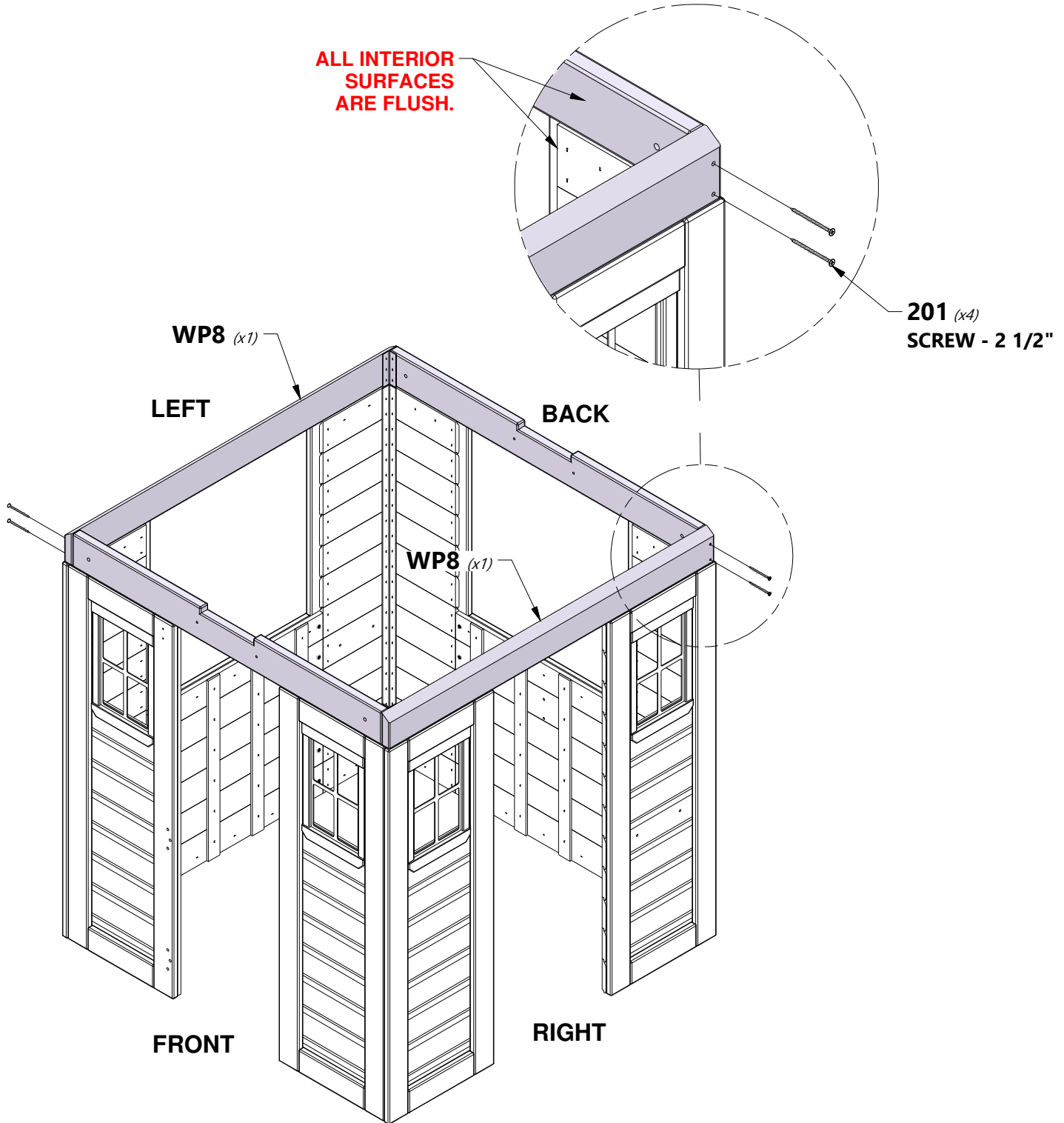

STEP 5 - PLAYHOUSE ASSEMBLY

QTY	PART NUMBER	DESCRIPTION
32	H100395	SCREW PFH 8x3/4 BLK

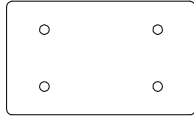

A4M00997
(x8) METAL CLEAT

USE PILOT HOLES,
AS SHOWN.

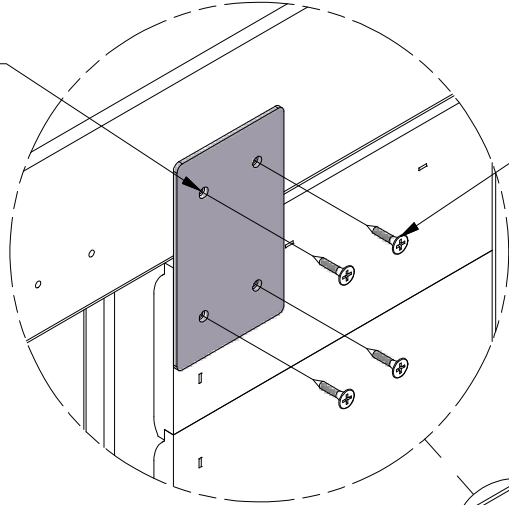

395 (x32)
SCREW - 3/4"

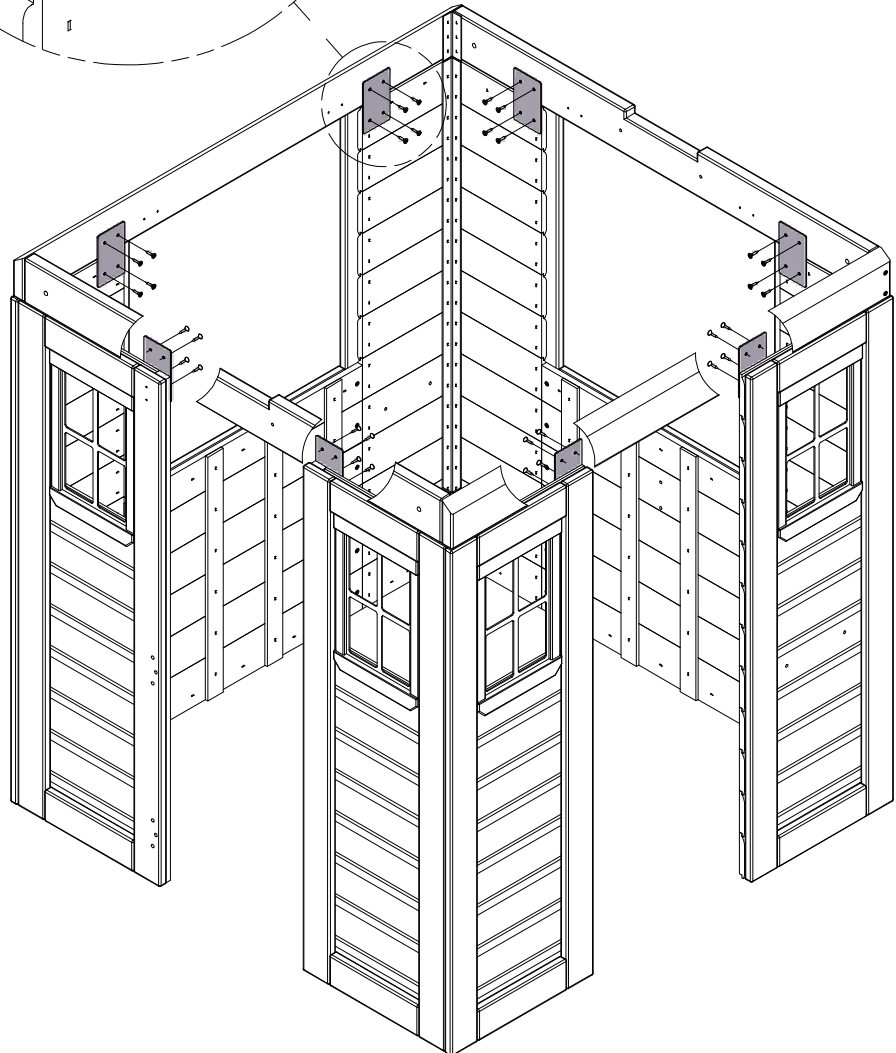

STEP 6 - PLAYHOUSE ASSEMBLY



L3 GABLE BOARD - W4L17862
 (x4) 5/8"x4 3/8"x25 3/8" (16x112x644)

QTY	PART NUMBER	DESCRIPTION
4	H100171	BOLT WH 1/4x1 BLK
4	H100399	NUT BARREL WH 1/4x7/8 BLK
4	H100400	WASHER LOCK EXT 8x15 BLK
4	H100405	WASHER LOCK EXT 6x15 BLK

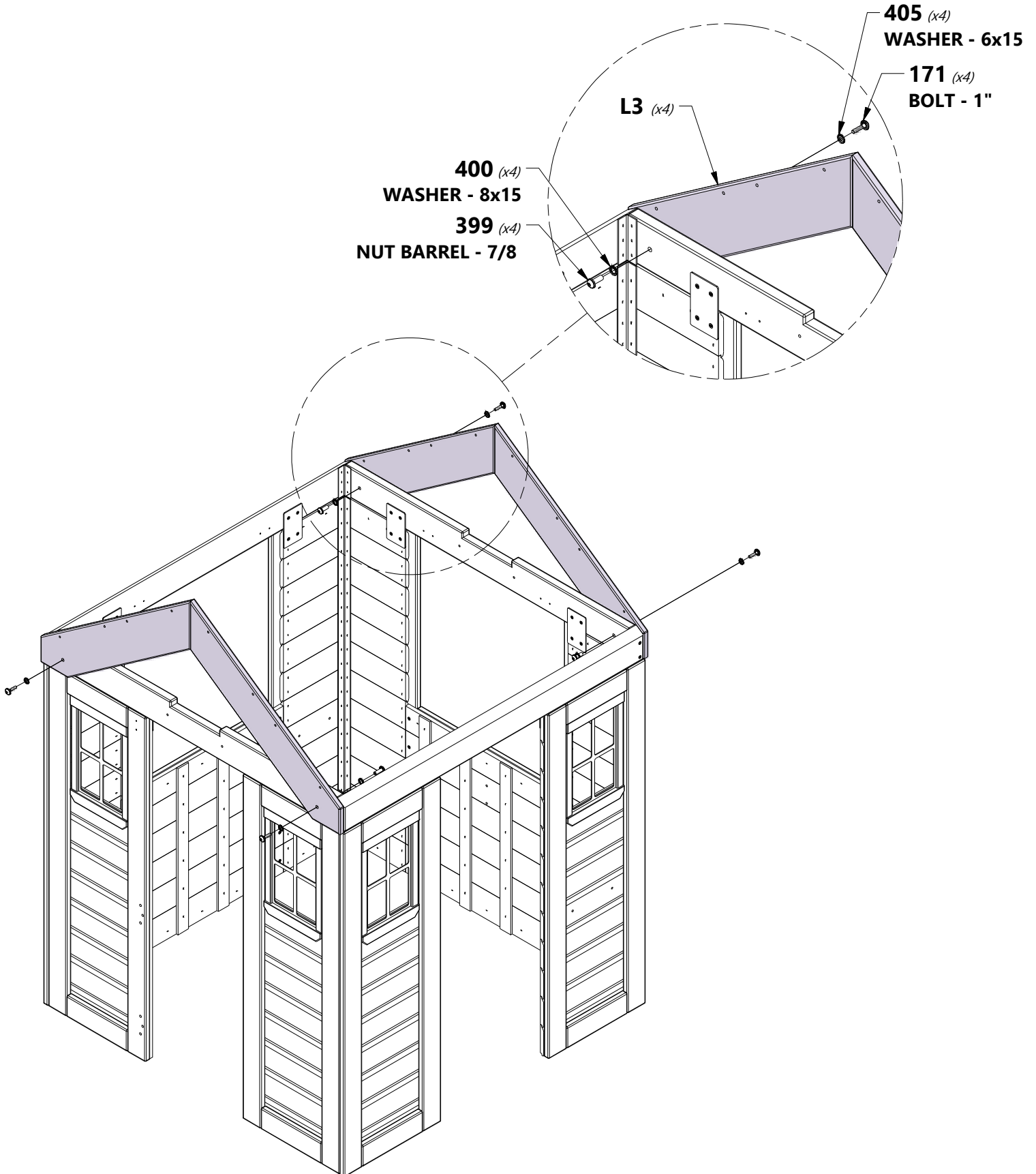

STEP 7 - PLAYHOUSE ASSEMBLY

QTY	PART NUMBER	DESCRIPTION
4	H100387	SCREW PFH 8x1-1/4 BLK
8	H100392	SCREW PWH 8x3/4 BLK

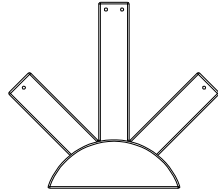

A100361
(x2) **PLASTIC SUNBURST**

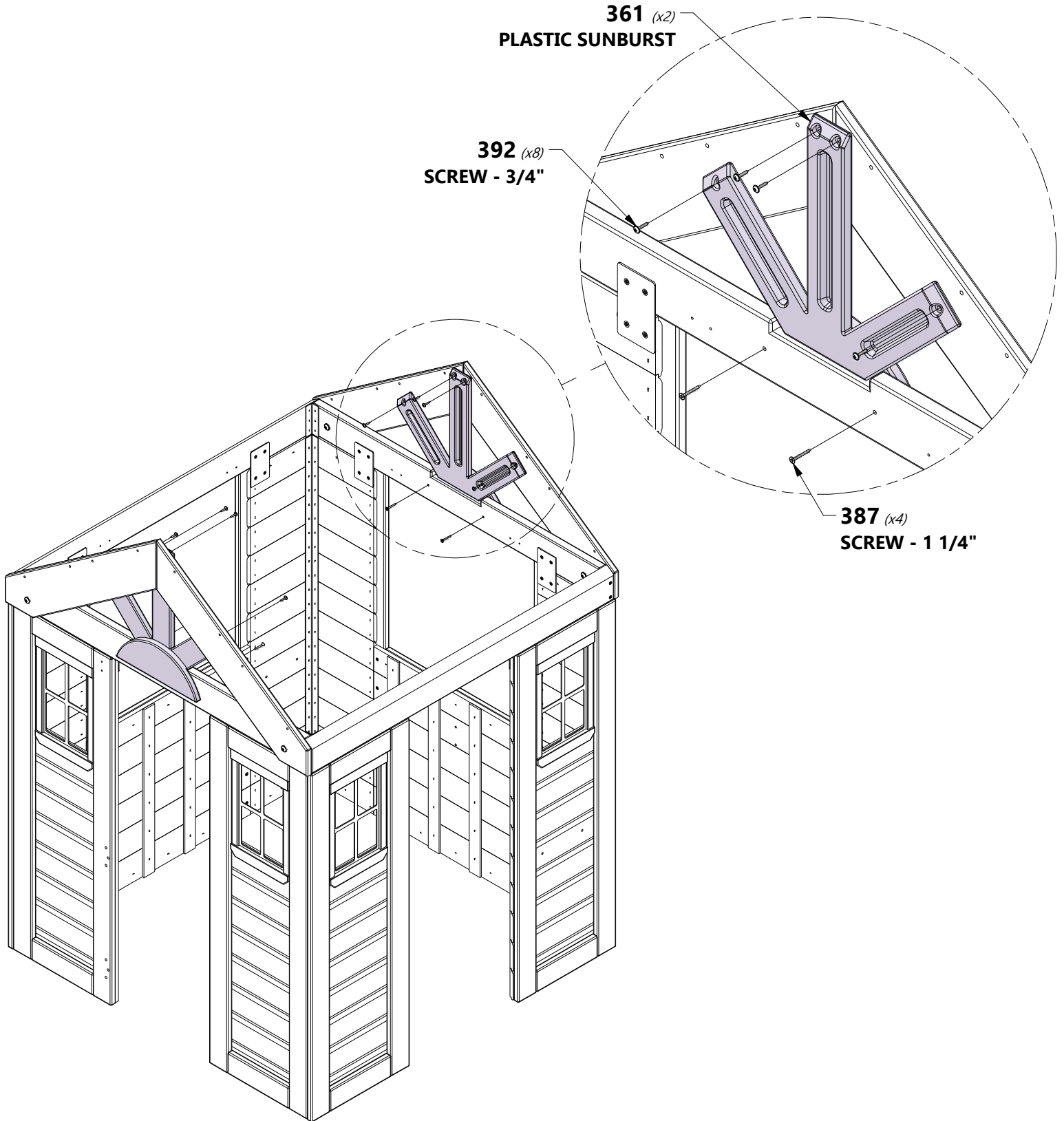

STEP 8 - PLAYHOUSE ASSEMBLY

QTY	PART NUMBER	DESCRIPTION
8	H100200	SCREW PFH 8x1-1/2 BLK



RP2 UPPER ROOF PANEL - W2A03864
(x2) 1 3/8"x12 3/4"x44 7/8" (35x324x1140)

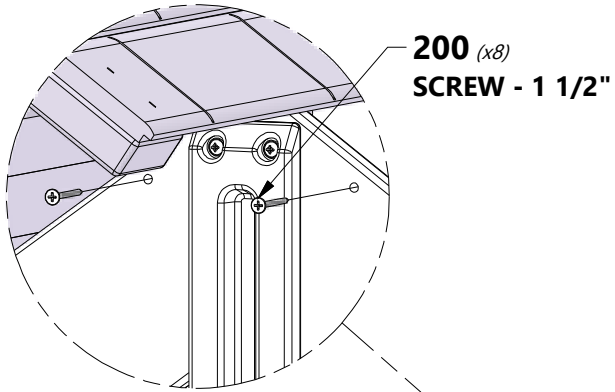

200 (x8)
SCREW - 1 1/2"

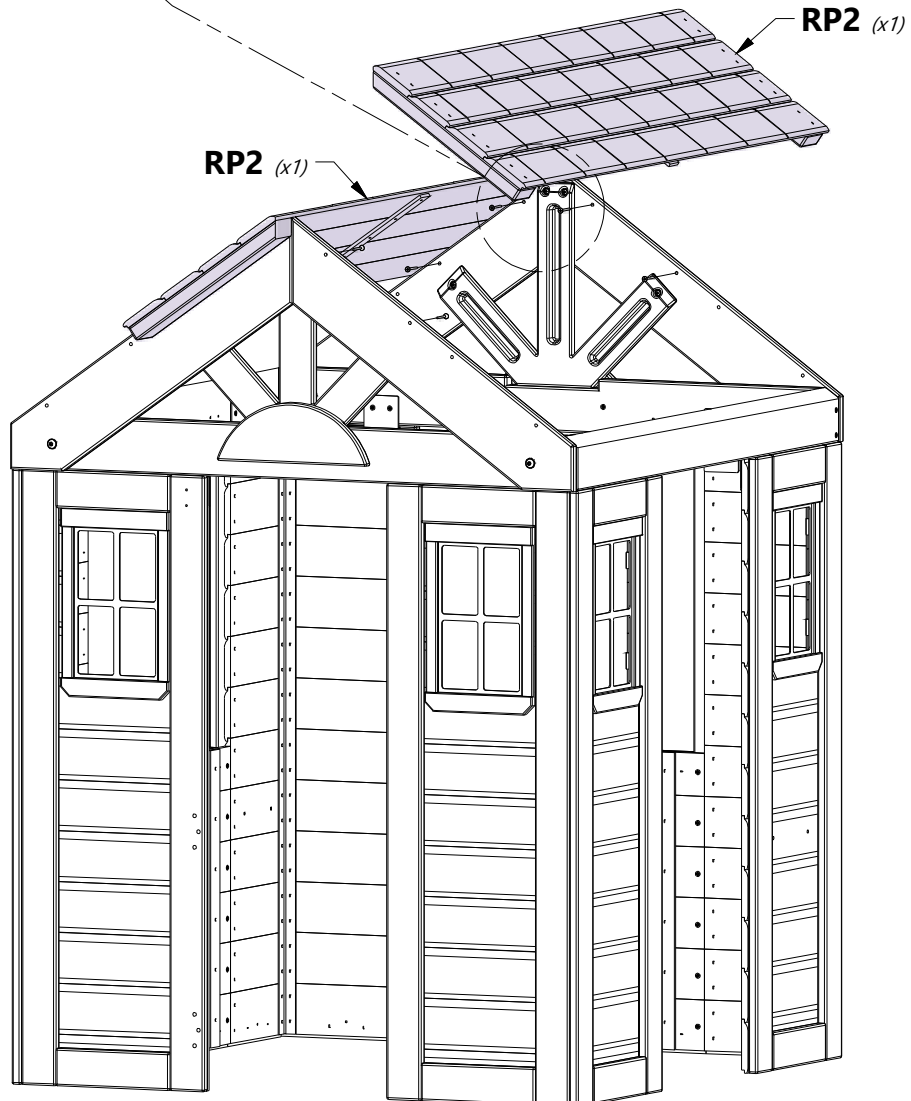

STEP 9 - PLAYHOUSE ASSEMBLY

QTY	PART NUMBER	DESCRIPTION
8	H100200	SCREW PFH 8x1-1/2 BLK

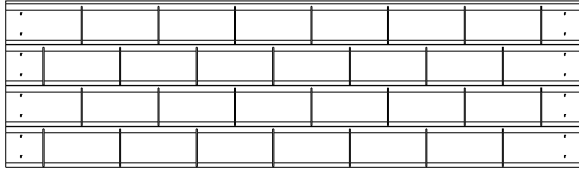

RP1 LOWER ROOF PANEL - W2A03863
 (x2) 1 3/8"x13"x44 7/8" (35x329x1140)

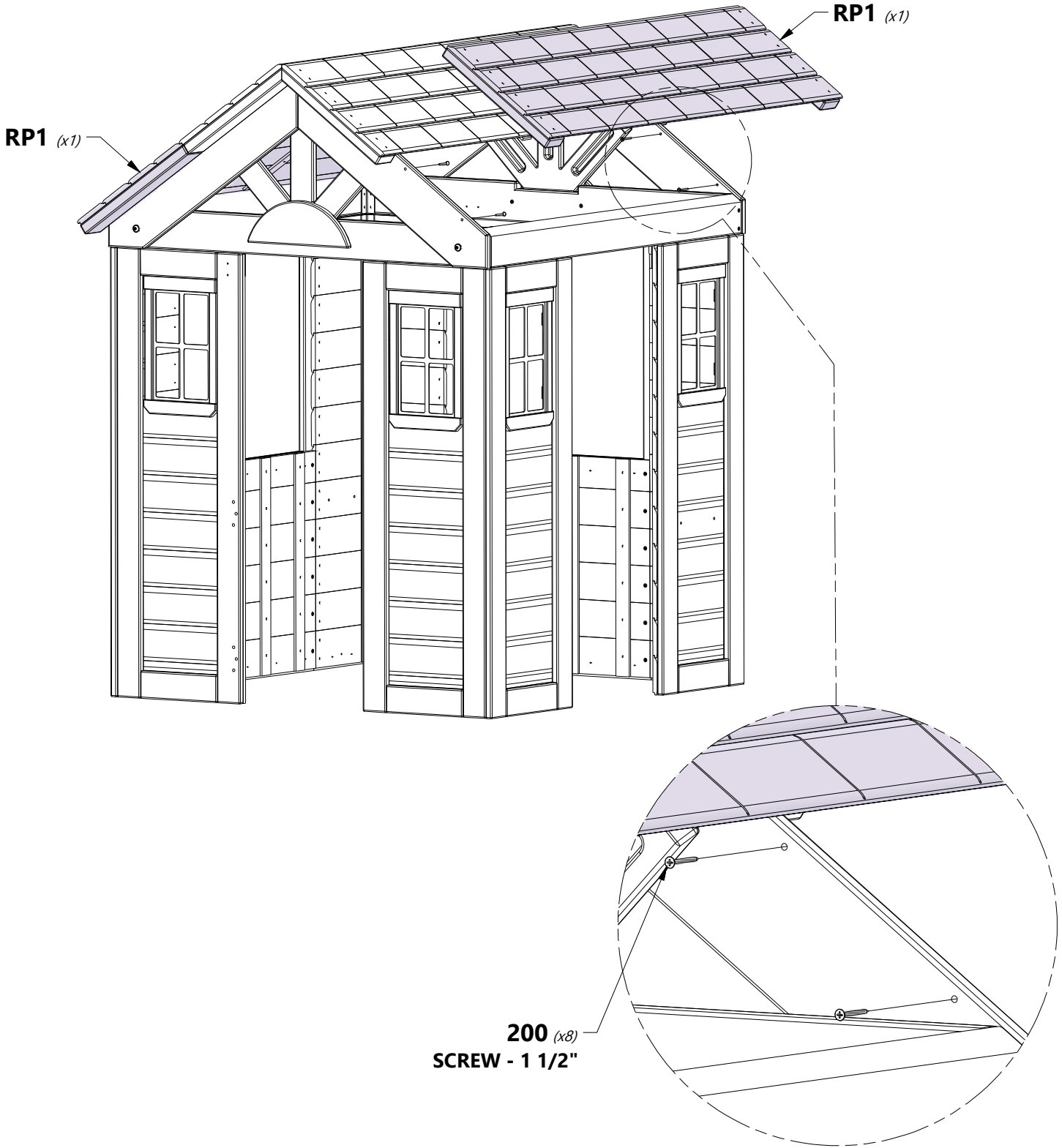

STEP 10 - PLAYHOUSE ASSEMBLY

QTY	PART NUMBER	DESCRIPTION
2	H100387	SCREW PFH 8x1-1/4 BLK

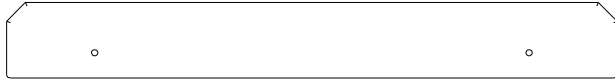

N2 WINDOW SHELF - W4L17871
(x1) 5/8"x2 3/8"x19 1/8" (16x60x485)

**DRILL PILOT HOLES FOR HARDWARE
USING A 1/8" (3mm) DRILL BIT.**

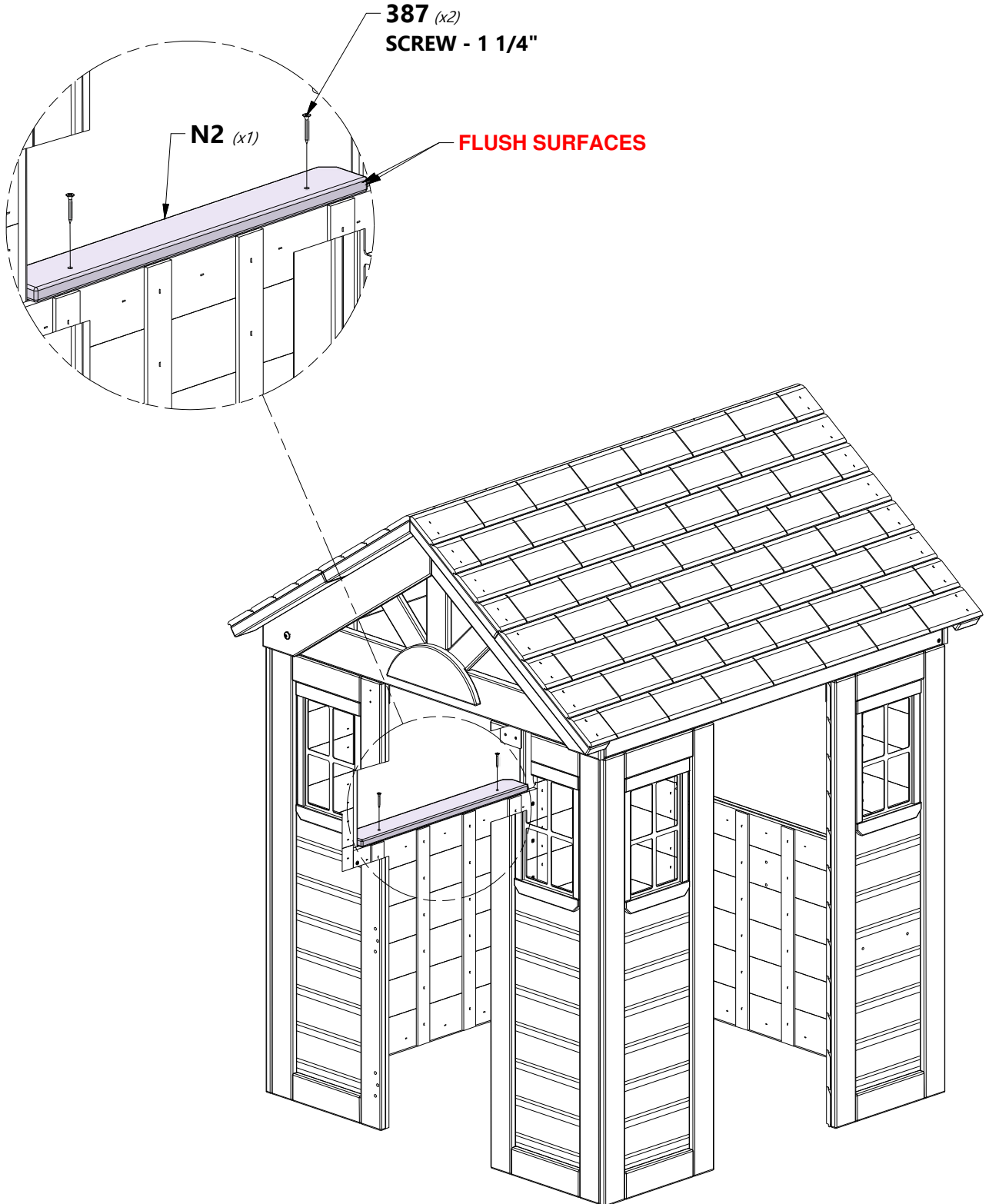

STEP 11 - PLAYHOUSE ASSEMBLY

QTY	PART NUMBER	DESCRIPTION
2	H100387	SCREW PFH 8x1-1/4 BLK

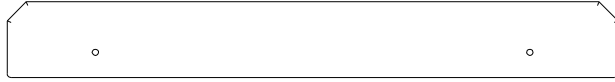

N2 WINDOW SHELF - W4L17871
(x1) 5/8"x2 3/8"x19 1/8" (16x60x485)

DRILL PILOT HOLES FOR HARDWARE USING A 1/8" (3mm) DRILL BIT.

387 (x2)
SCREW - 1 1/4"

FLUSH SURFACES

N2 (x1)

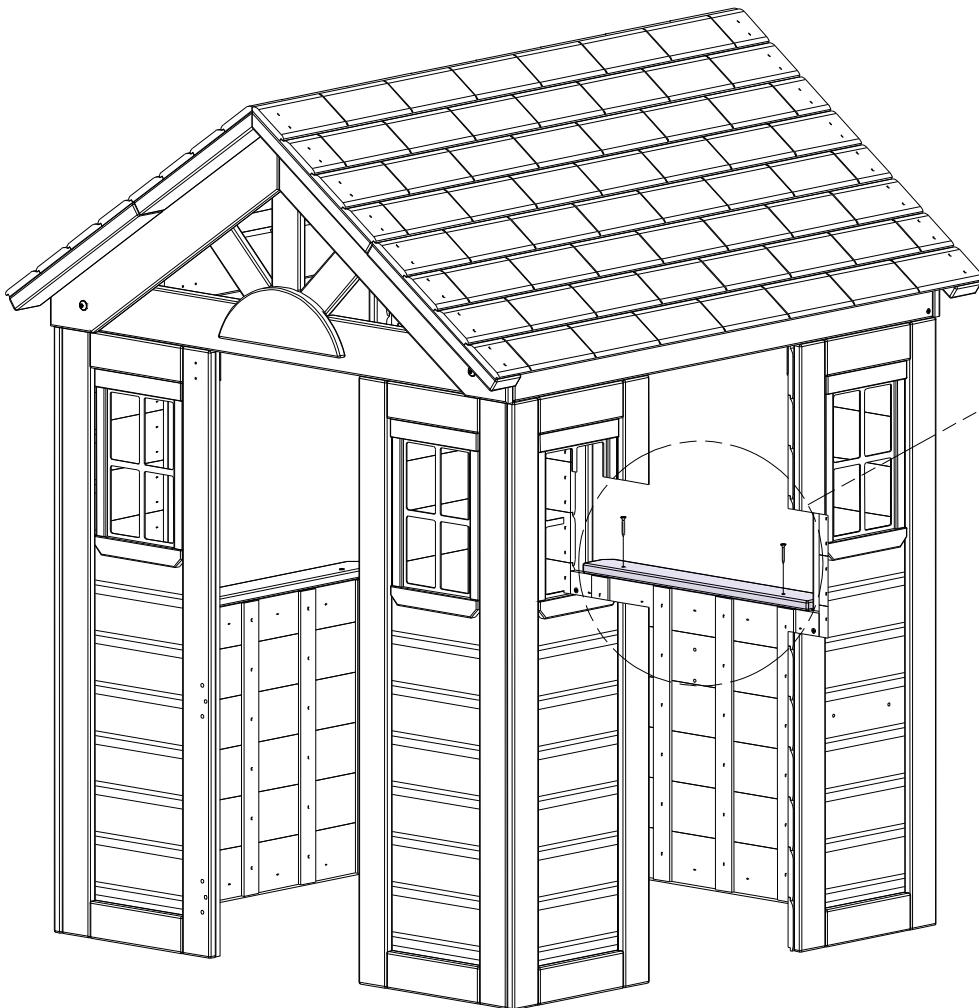
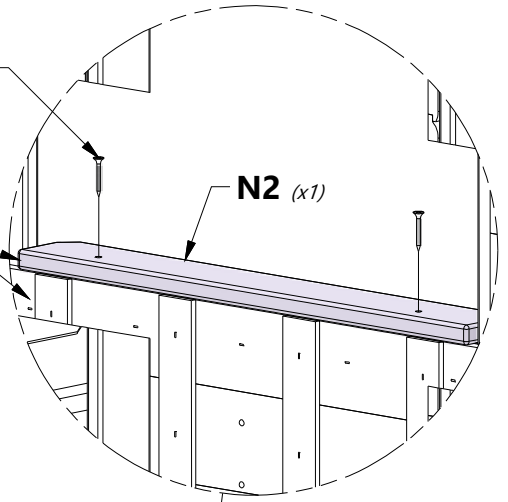

STEP 12 - PLAYHOUSE ASSEMBLY

QTY	PART NUMBER	DESCRIPTION
8	H100202	SCREW PWH 8x5/8 BLK

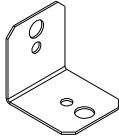

A4M00555
(x8) 90° L-BRACKET - BLK

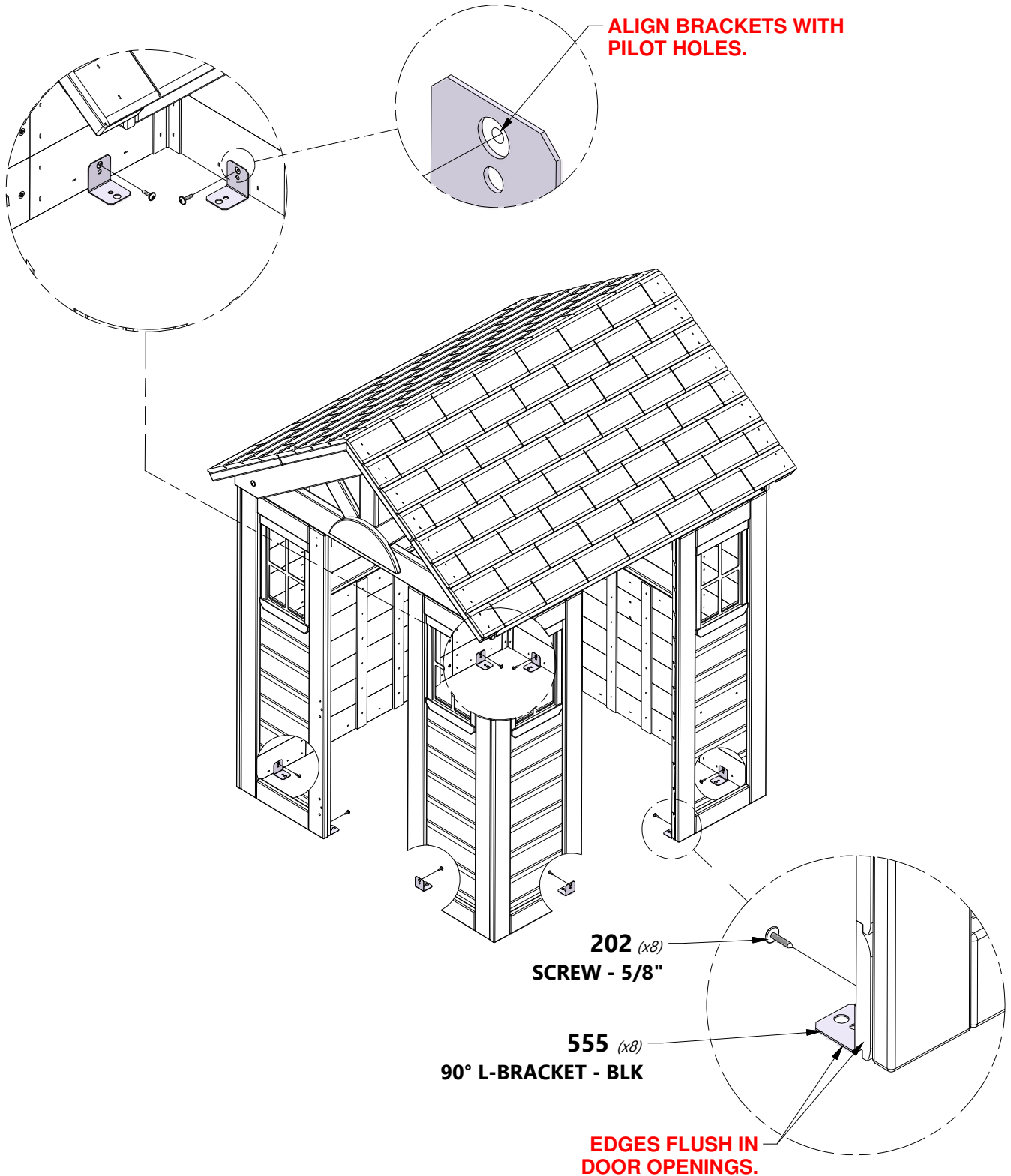

STEP 13 - PLAYHOUSE ASSEMBLY

QTY	PART NUMBER	DESCRIPTION
2	H100200	SCREW PFH 8x1-1/2 BLK



H3 COUNTER TOP SUPPORT - W4L17873
(x1) 1"x3 3/8"x8 3/8" (24x86x214)

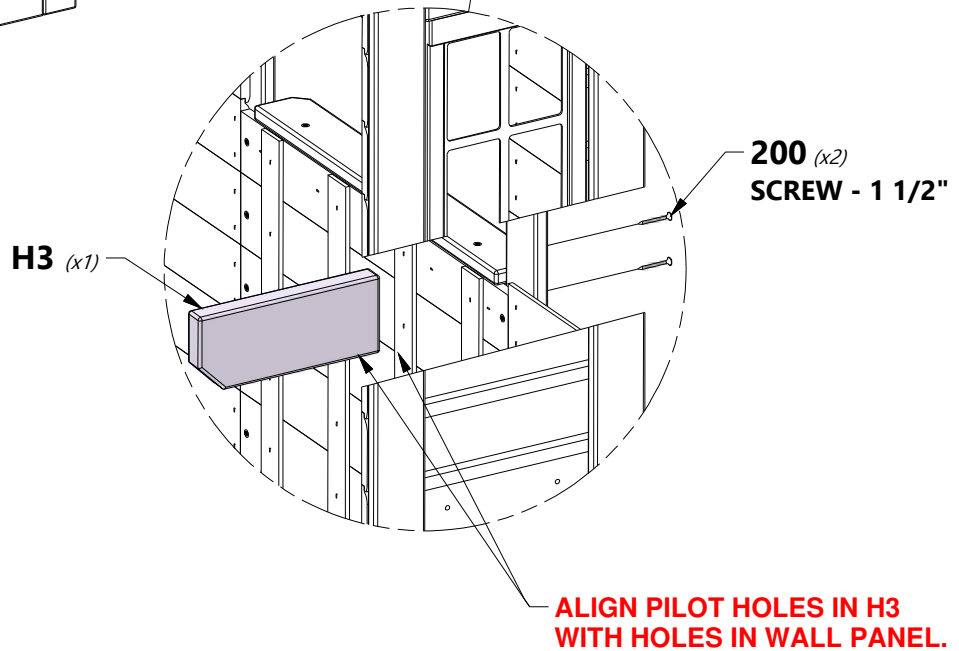
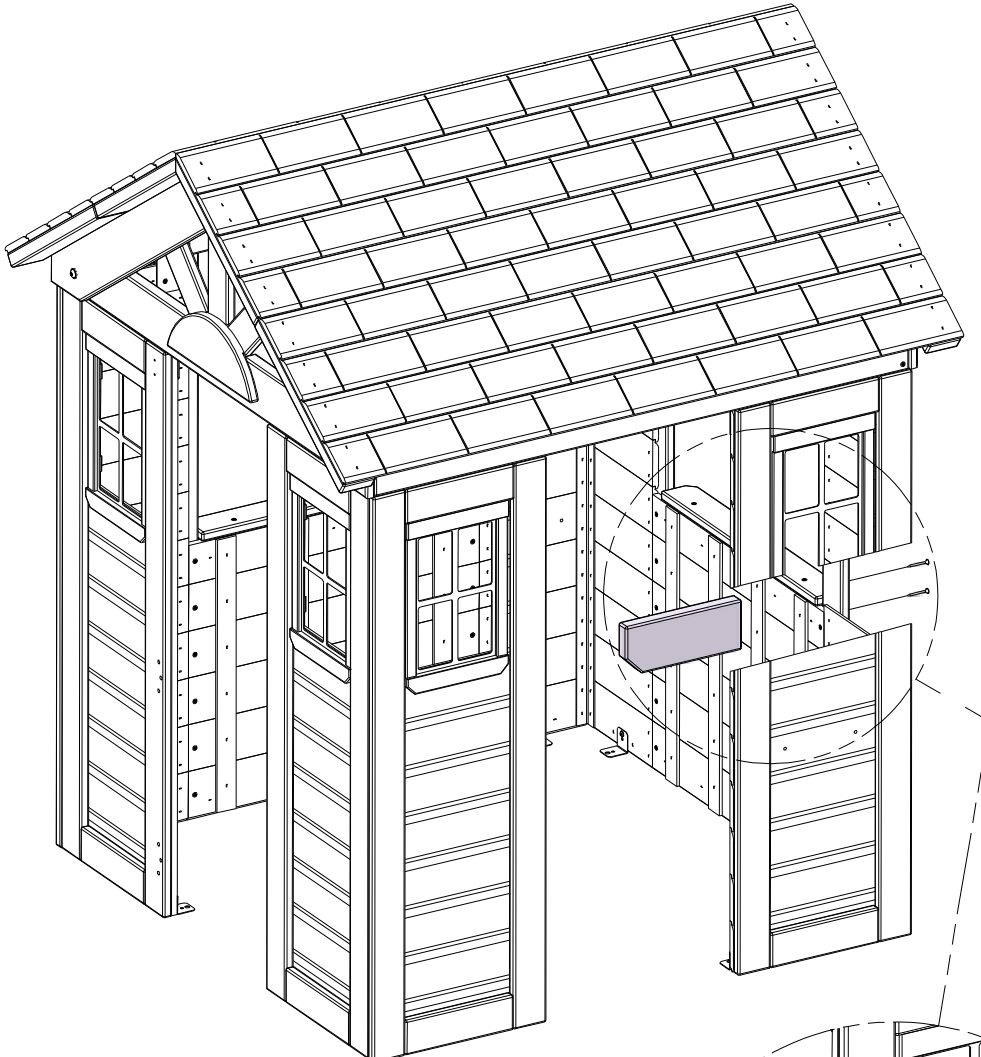

STEP 14 - PLAYHOUSE ASSEMBLY

QTY	PART NUMBER	DESCRIPTION
4	H100387	SCREW PFH 8x1-1/4 BLK



J3 COUNTER TOP SUPPORT - W4L17859
 (x2) 1"x2 3/8"x9 1/4" (24x60x234)

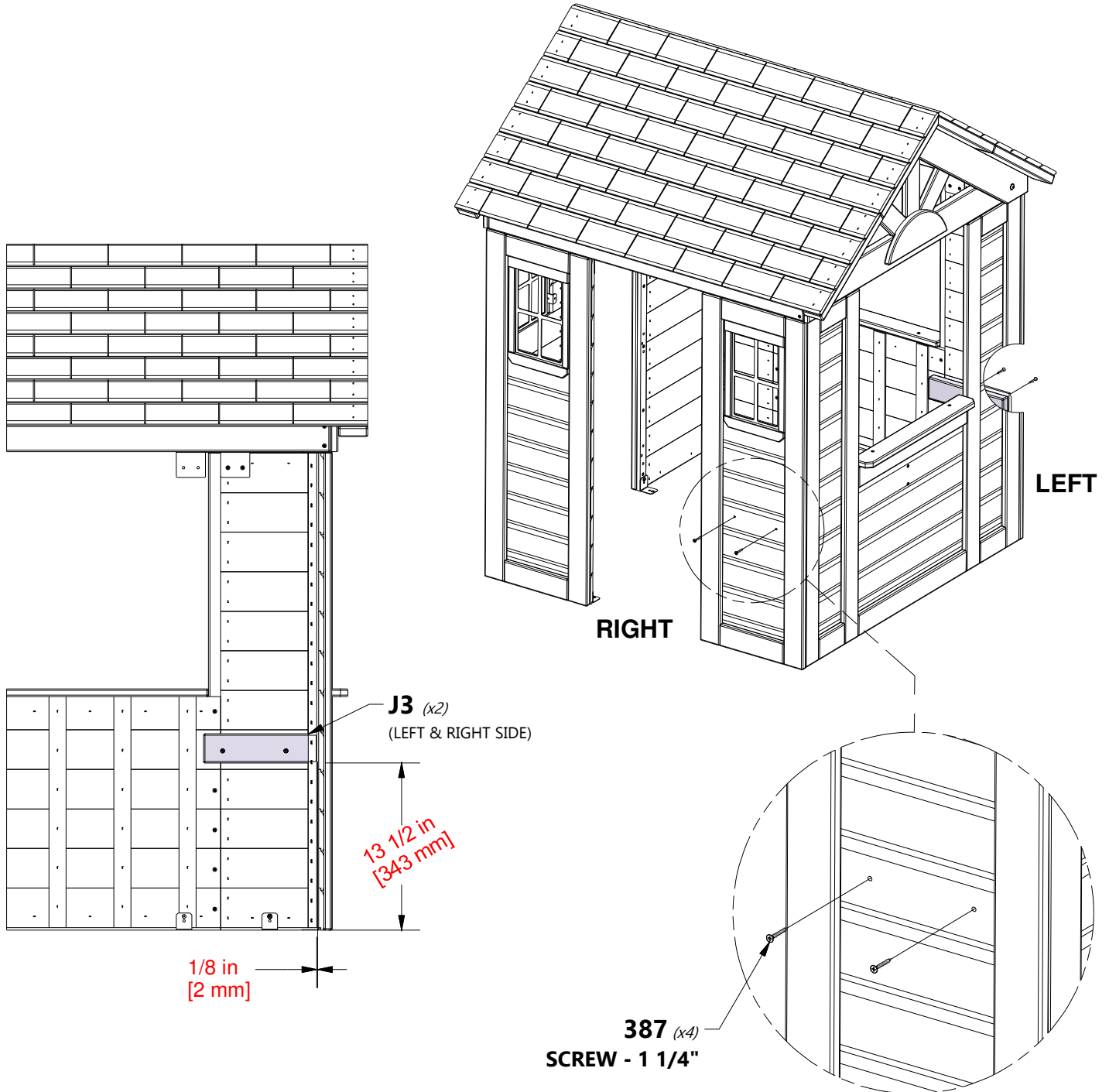

STEP 15 - PLAYHOUSE ASSEMBLY

QTY	PART NUMBER	DESCRIPTION
10	H100200	SCREW PFH 8x1-1/2 BLK

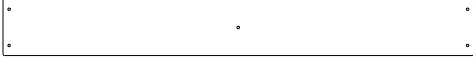

Q1 COUNTER TOP - W4L17863
 (x2) 1"x4 3/8"x36 3/4" (24x112x934)

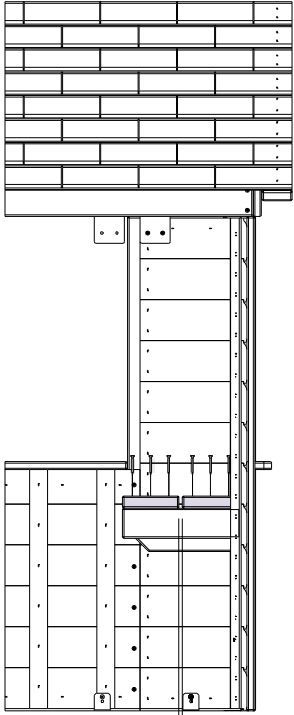

1/4 in
 [7 mm]

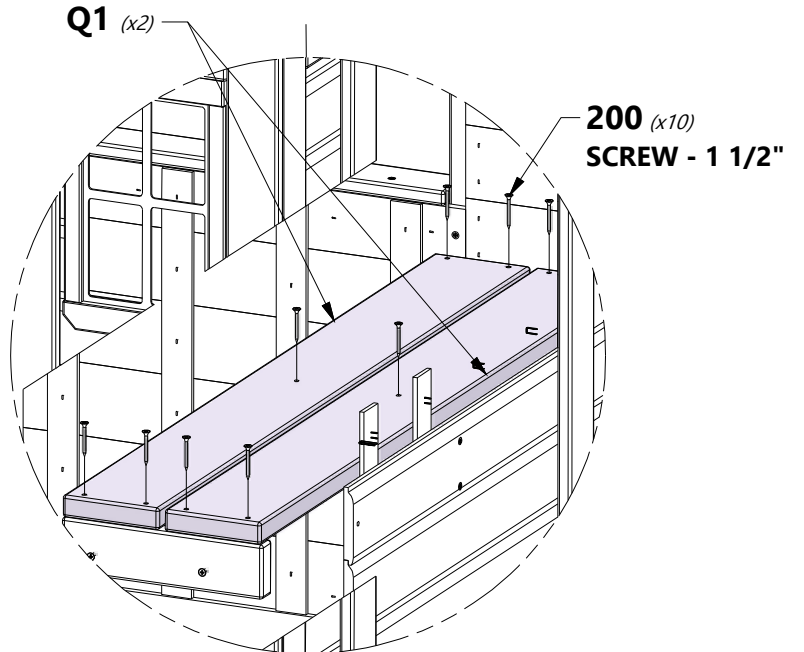
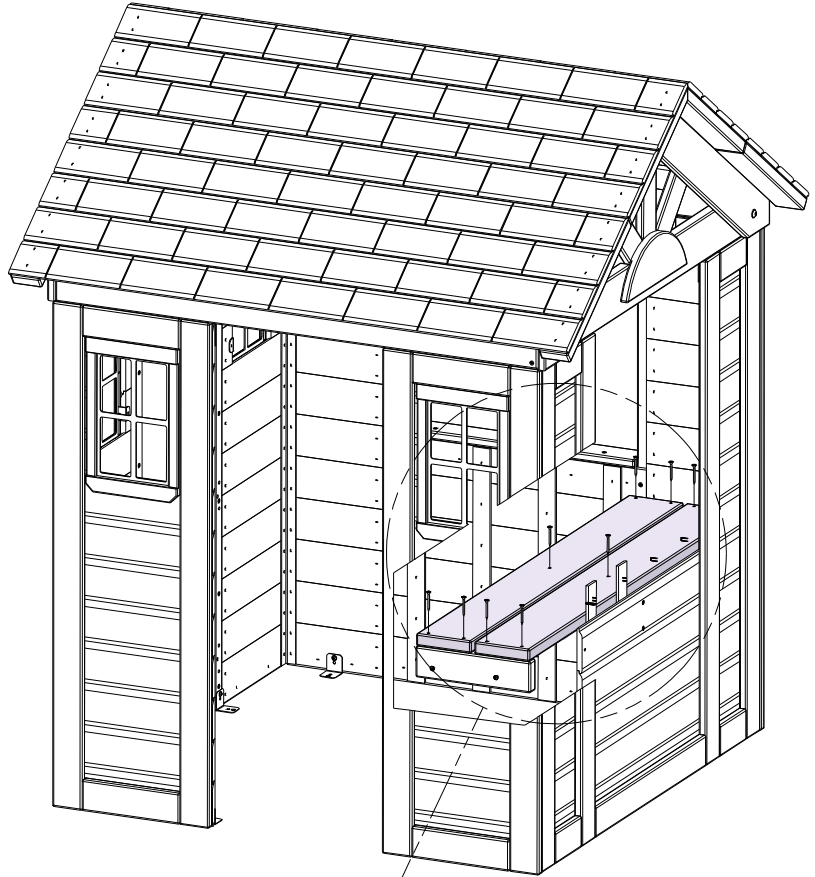

STEP 16 - PLAYHOUSE ASSEMBLY

QTY	PART NUMBER	DESCRIPTION
2	H100200	SCREW PFH 8x1-1/2 BLK

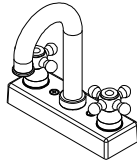

A6P00024
(x1) **FAUCET KIT**

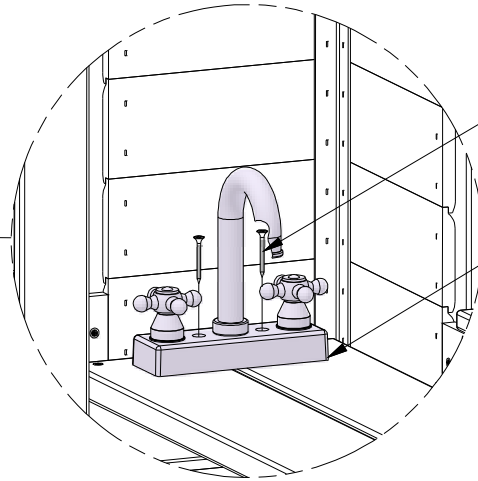
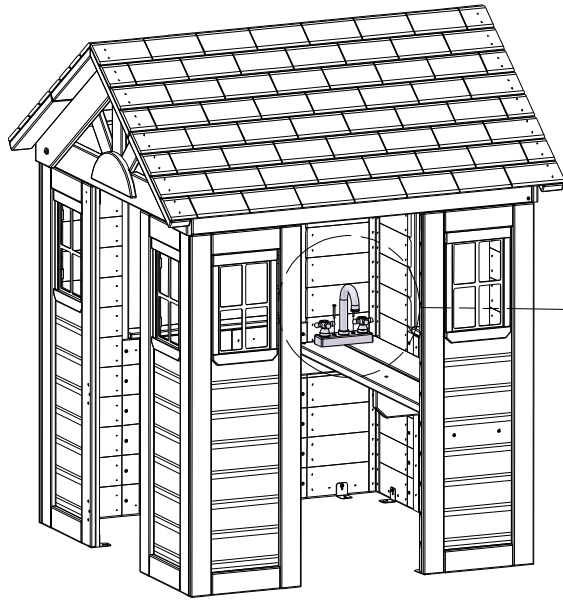

200 (x2)
SCREW - 1 1/2"

024 (x1)
FAUCET KIT

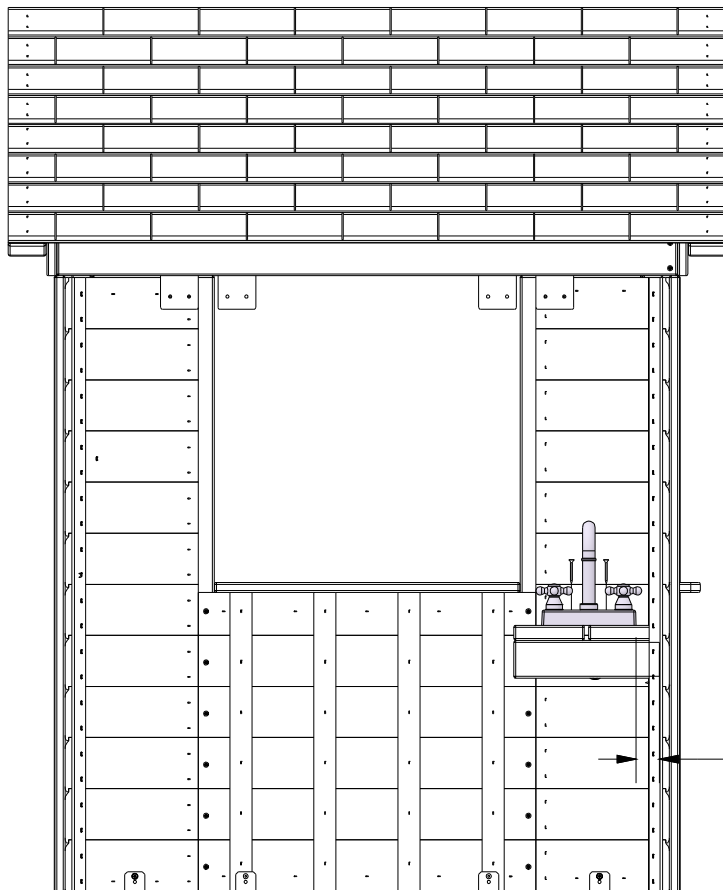

1 1/2 in
[37 mm]
(FAUCET LOCATION)

STEP 17 - PLAYHOUSE ASSEMBLY

QTY	PART NUMBER	DESCRIPTION
2	H100202	SCREW PWH 8x5/8 BLK

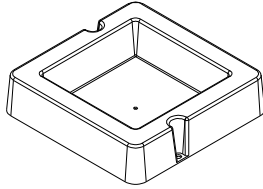

A6P00032
(x1) SURFACE MOUNT BASIN

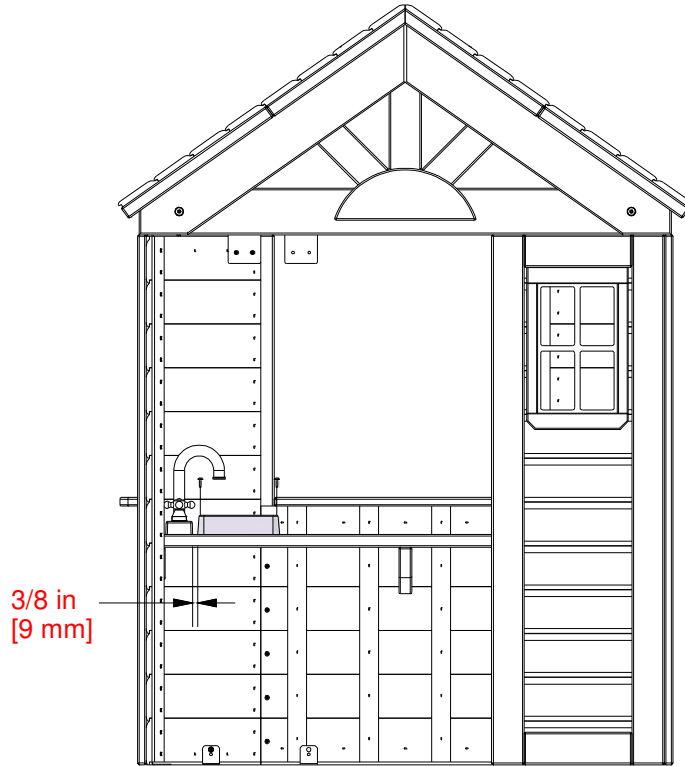

3/8 in
[9 mm]

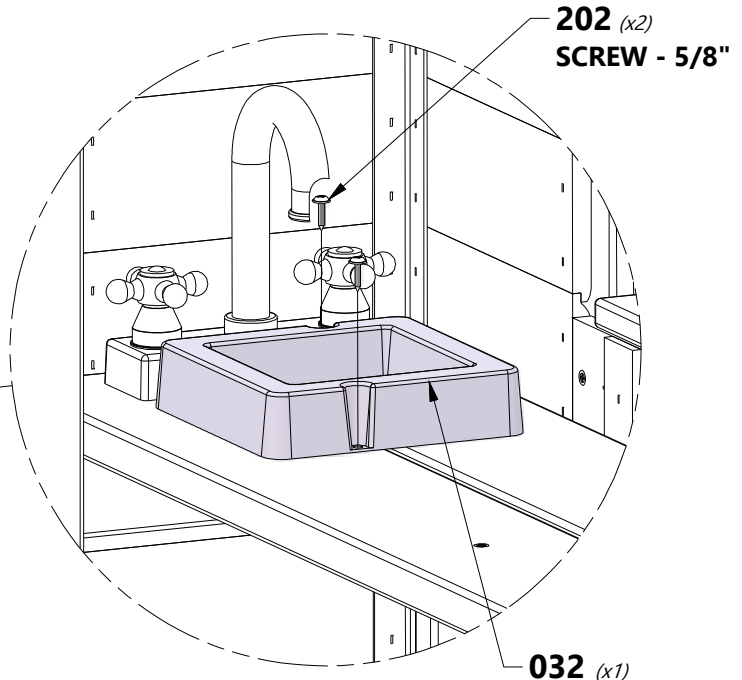
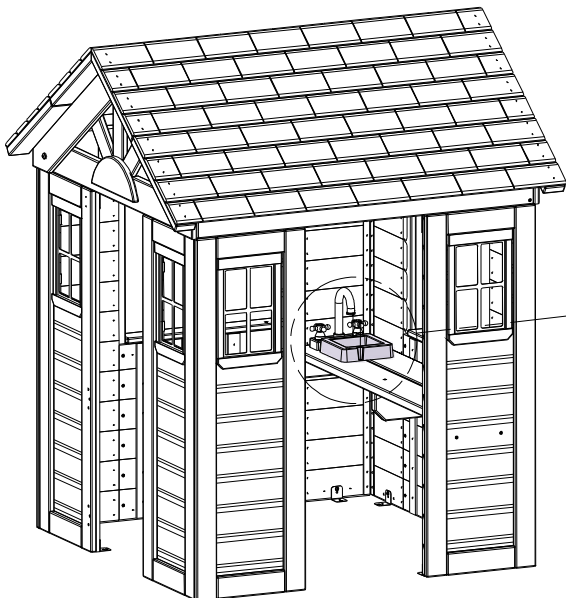

032 *(x1)*
SURFACE MOUNT BASIN

STEP 18 - PLAYHOUSE ASSEMBLY

QTY	PART NUMBER	DESCRIPTION
8	H100387	SCREW PFH 8x1-1/4 BLK



S2 WINDOW TRIM - W4L17875
(x2) 1"x1"x21 1/2" (24x24x545)



S3 WINDOW TRIM - W4L17876
(x2) 1"x1"x23 3/8" (24x24x594)

DRILL PILOT HOLES FOR HARDWARE
USING A 1/8" (3mm) DRILL BIT.

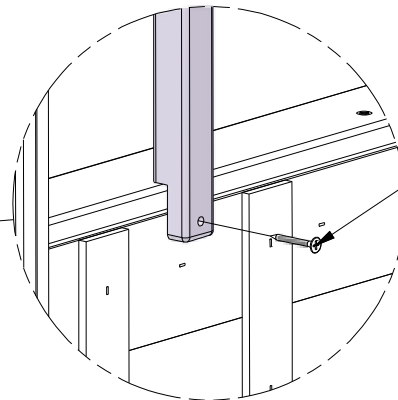
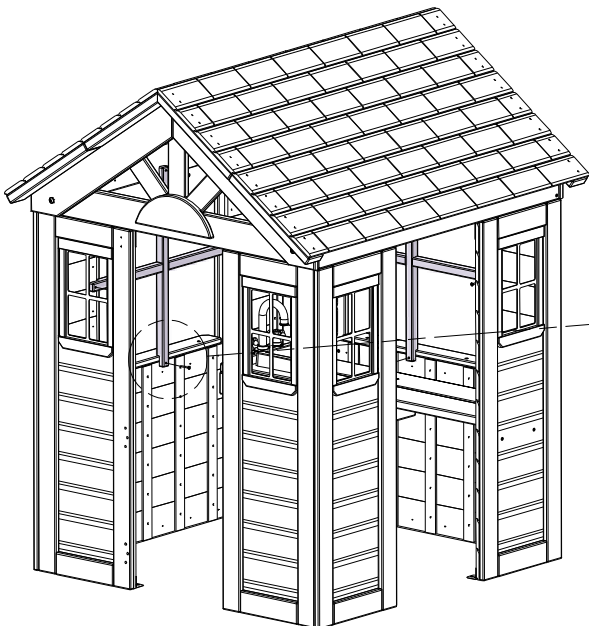
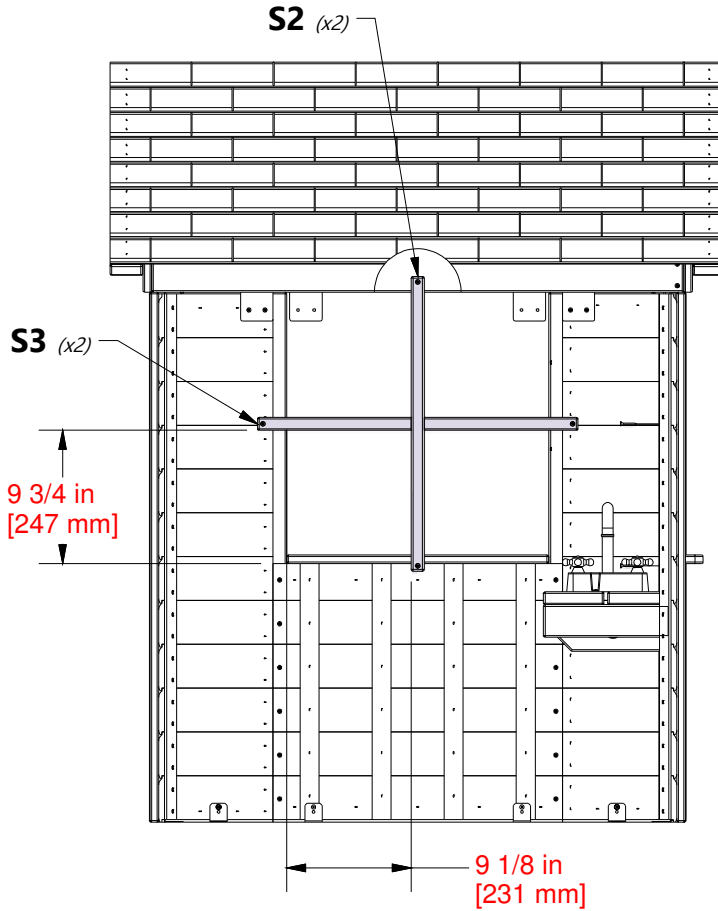

387 (x8)
SCREW - 1 1/4"

STOVE ASSEMBLY

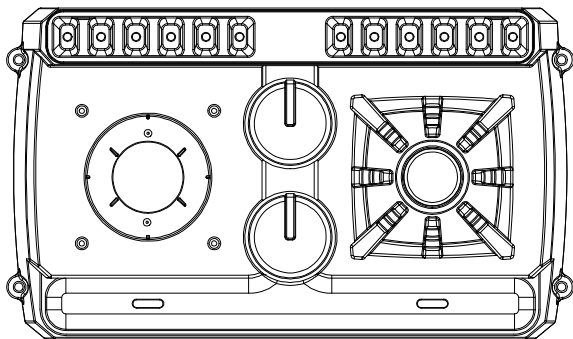

A6P00335
(x1) | **STOVE BASE**

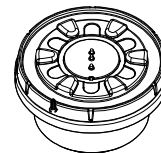

A6P00330
(x1) | **INDUCTIVE BURNER KIT**

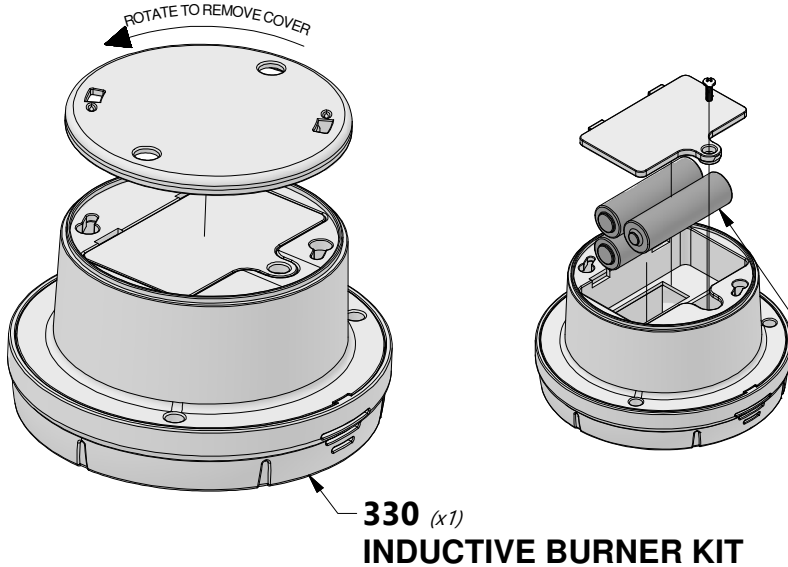

330 (x1)
INDUCTIVE BURNER KIT

NOTE: FCC LABEL
 -DO NOT MIX OLD AND NEW BATTERIES.
 -DO NOT MIX ALKALINE, STANDARD (CARBON-ZINC), OR RECHARGEABLE (NI-CAD, NI-MH, ETC.) BATTERIES.
 -NON-RECHARGEABLE BATTERIES ARE NOT TO BE RECHARGED.
 -ONLY BATTERIES OF THE SAME OR EQUIVALENT TYPE AS RECOMMENDED ARE TO BE USED.
 -BATTERIES ARE TO BE INSERTED WITH THE CORRECT POLARITY.
 -EXHAUSTED BATTERIES ARE TO BE REMOVED FROM THE TOY OR IF THE TOY IS TO BE LEFT UNUSED FOR A LONG TIME.
 -THE SUPPLY TERMINALS ARE NOT TO BE SHORT-CIRCUITED.
 -RECHARGEABLE BATTERIES ARE TO BE REMOVED FROM TOY BEFORE BEING CHARGED.
 -RECHARGEABLE BATTERIES ARE ONLY TO BE CHARGED UNDER ADULT SUPERVISION.

"AA" BATTERY (x3)
(Not Included)

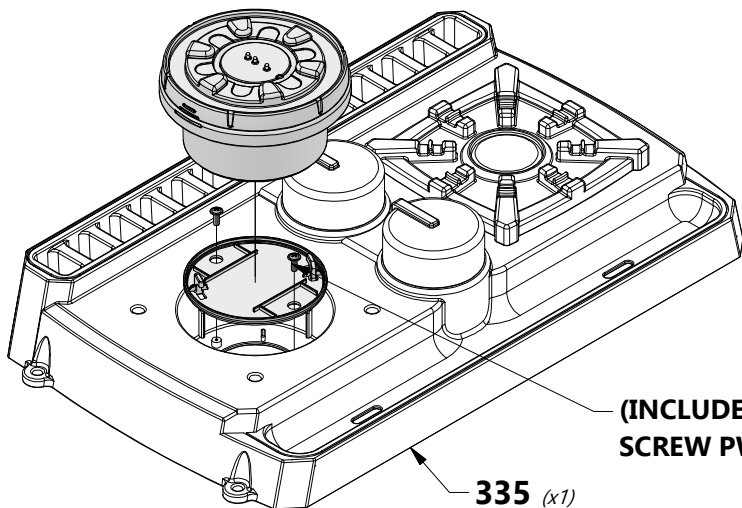

(INCLUDED WITH KIT) (x2)
SCREW PWH 4x5/16

335 (x1)
STOVE BASE

NOTE:
 THIS DEVICE COMPLIES WITH PART 15 OF THE FCC RULES. OPERATION IS SUBJECT TO THE FOLLOWING TWO CONDITIONS:
 (1) THIS DEVICE MAY NOT CAUSE HARMFUL INTERFERENCE,
 (2) THIS DEVICE MUST ACCEPT ANY INTERFERENCE RECEIVED, INCLUDING INTERFERENCE THAT MAY CAUSE UNDESIRABLE OPERATION.

NOTE:
 FIRST INSTALL THE COVER REMOVED ABOVE WITH THE INCLUDED HARDWARE. INSTALL THE BURNER BY TWISTING IT CLOCKWISE TO LOCK IT IN PLACE.

STEP 19 - PLAYHOUSE ASSEMBLY

QTY	PART NUMBER	DESCRIPTION
4	H100797	SCREW PWH 8x1 BLK

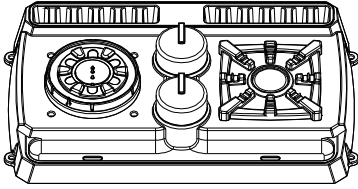

A6P00335
(x1) **STOVE BASE**

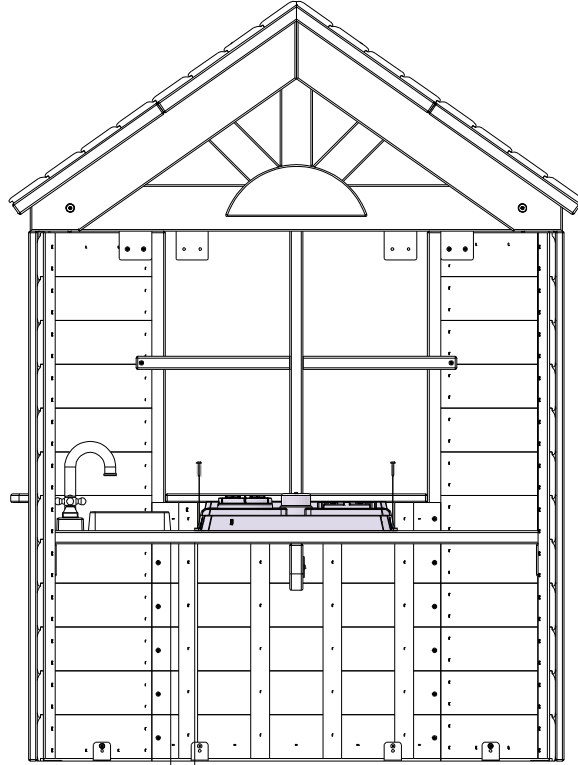

1 3/4 in
[45 mm]

335 (x1)
STOVE BASE

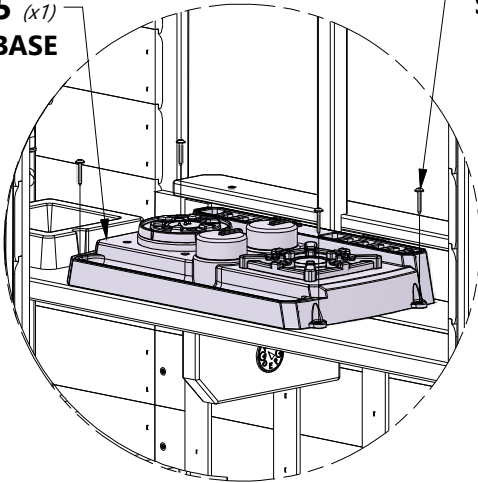

797 (x4)
SCREW - 1"

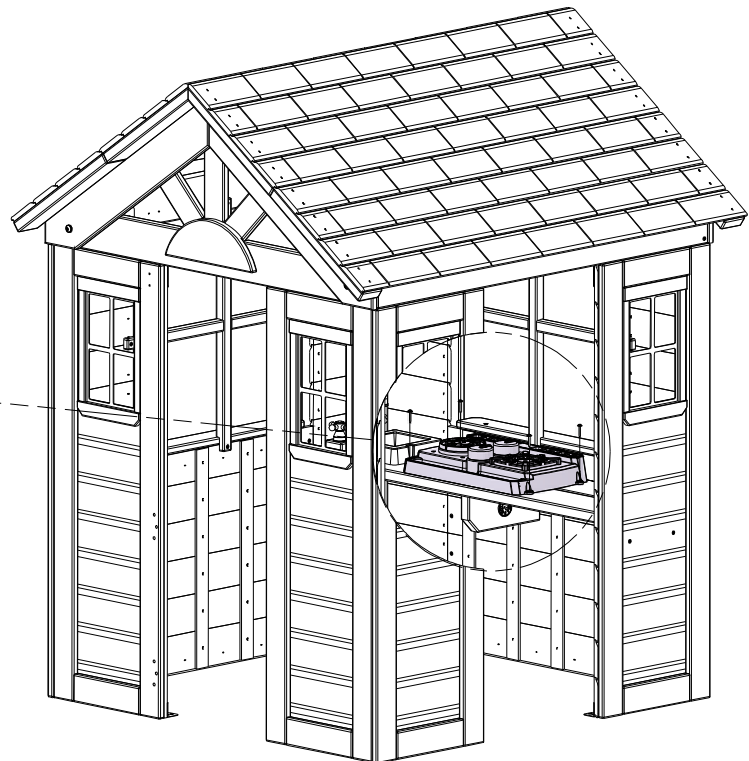

STEP 20 - PLAYHOUSE ASSEMBLY

QTY	PART NUMBER	DESCRIPTION
4	H100387	SCREW PFH 8x1-1/4 BLK

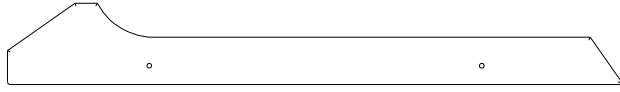

M33 FASCIA BOARD - W4L17867
(x2) 5/8"x3 3/8"x25 5/8" (16x86x652)

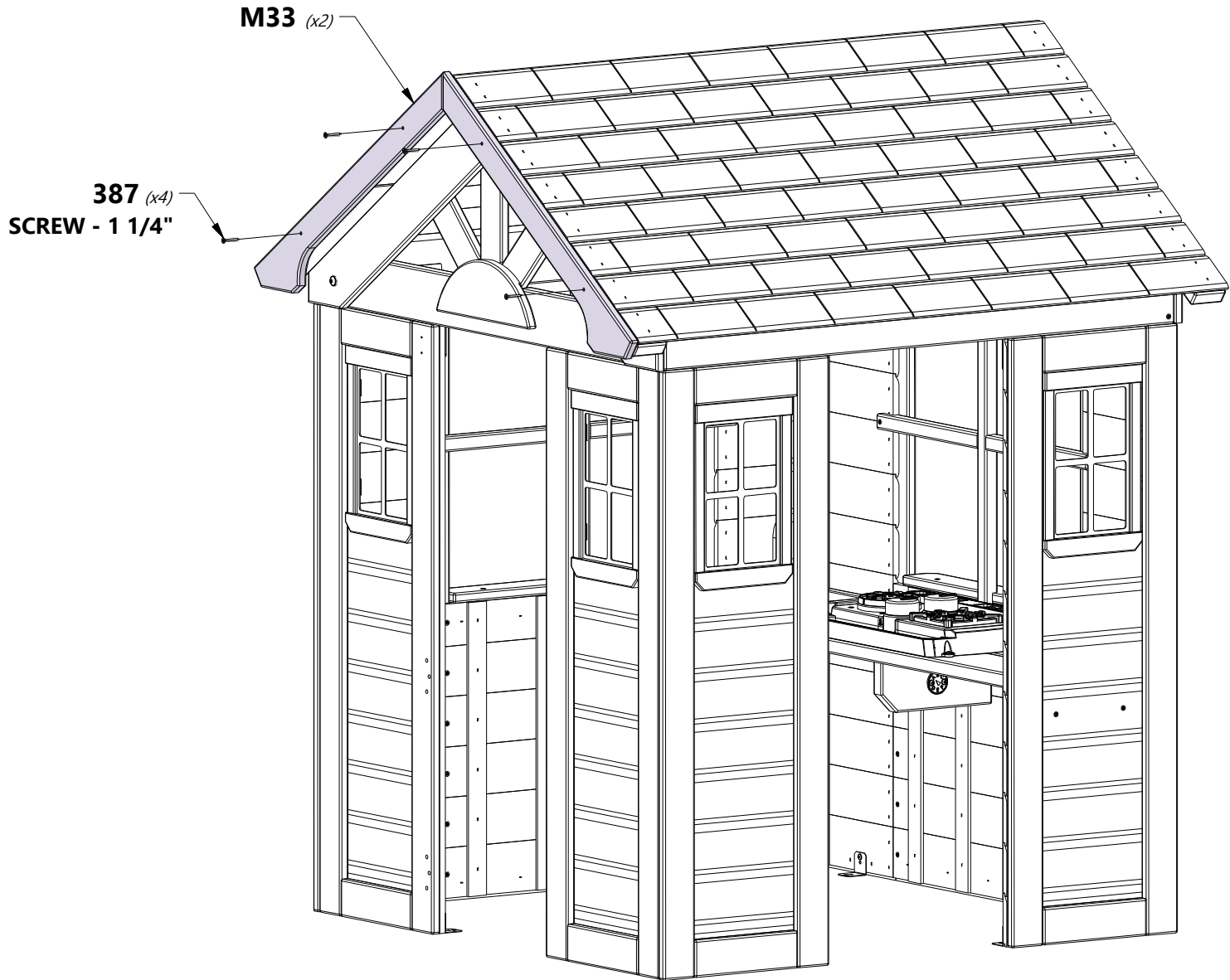

STEP 21 - PLAYHOUSE ASSEMBLY

QTY	PART NUMBER	DESCRIPTION
4	H100387	SCREW PFH 8x1-1/4 BLK

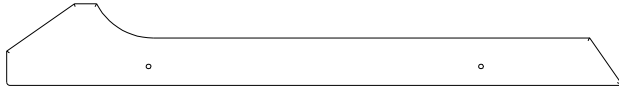

M33 FASCIA BOARD - W4L17867
(x2) 5/8"x3 3/8"x25 5/8" (16x86x652)

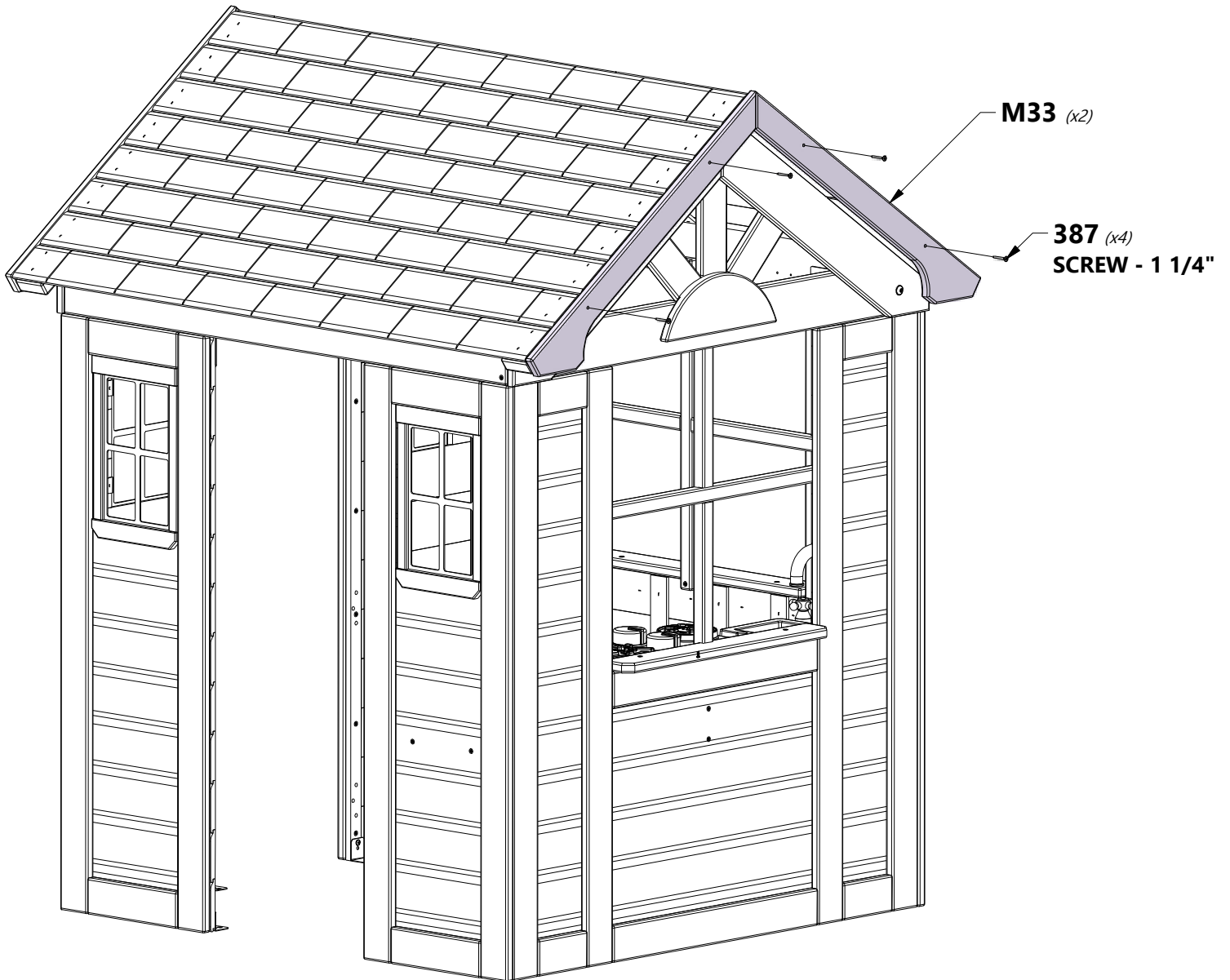

STEP 22 - PLAYHOUSE ASSEMBLY

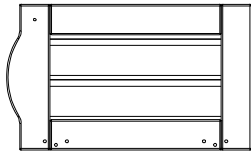

DP1 DOOR PANEL - W2A03865
(x1) 1 1/8"x19 1/8"x11 3/8" (27x486x288)

QTY	PART NUMBER	DESCRIPTION
1	H100382	SCREW PFH 8x1 3/4 BLK
2	H100395	SCREW PFH 8x3/4 BLK
6	H100804	T-NUT 8/32
6	H100806	SCREW POH-MS 8/32x1 1/8" BLK



A6P00067
(x1) **KNOB - BLK**



A4M00933
(x1) **DOOR STOP**

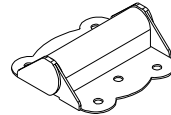

A4M00994
(x1) **HINGE (DOOR, NON-SPRING LOADED)**

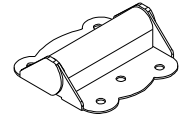

A4M00624
(x1) **HINGE (DOOR, SPRING LOADED)**

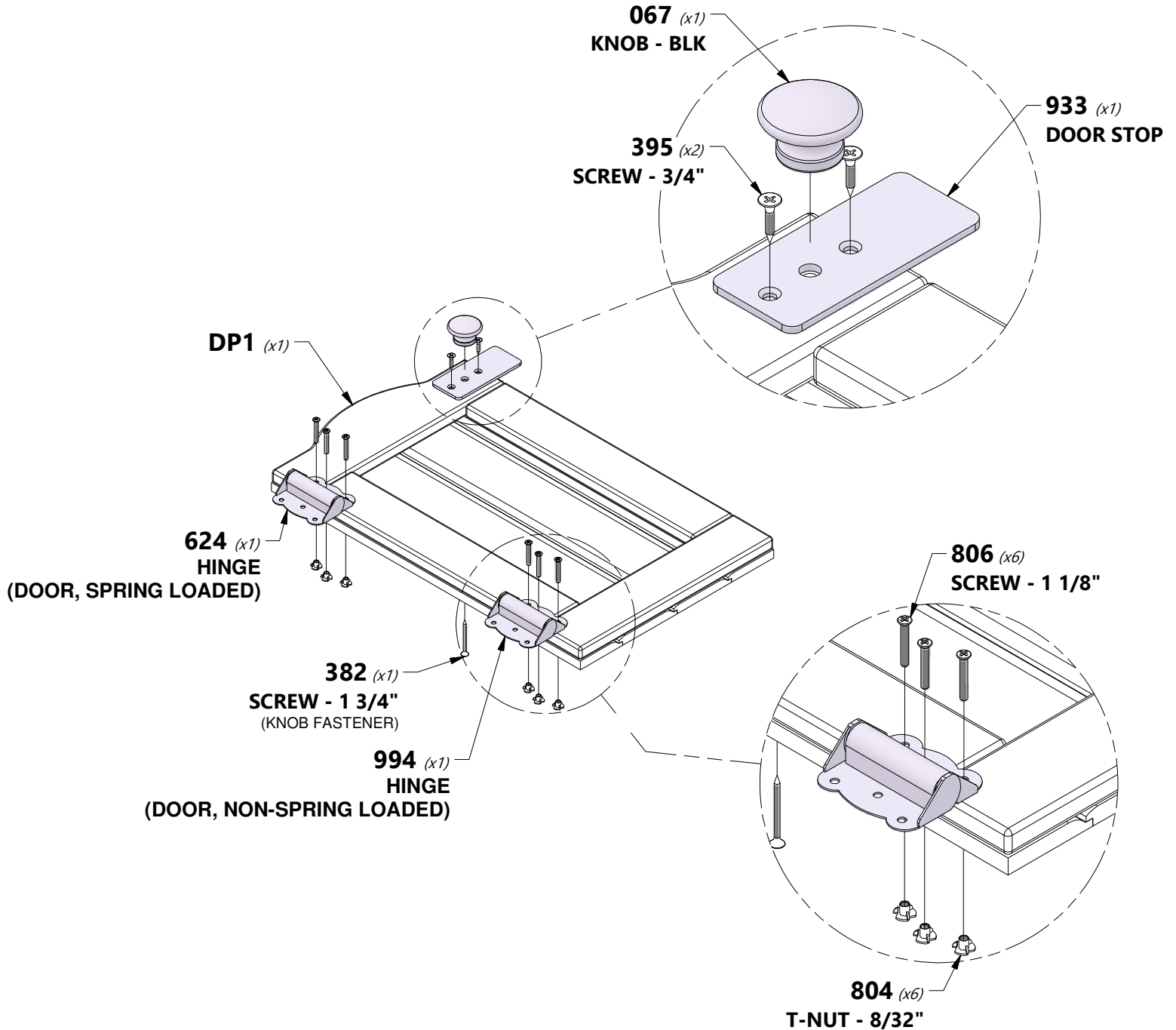

STEP 23 - PLAYHOUSE ASSEMBLY

QTY	PART NUMBER	DESCRIPTION
6	H100804	T-NUT 8/32
6	H100806	SCREW POH-MS 8/32x1 1/8" BLK

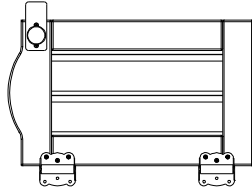

(x1) DOOR SUBASSEMBLY

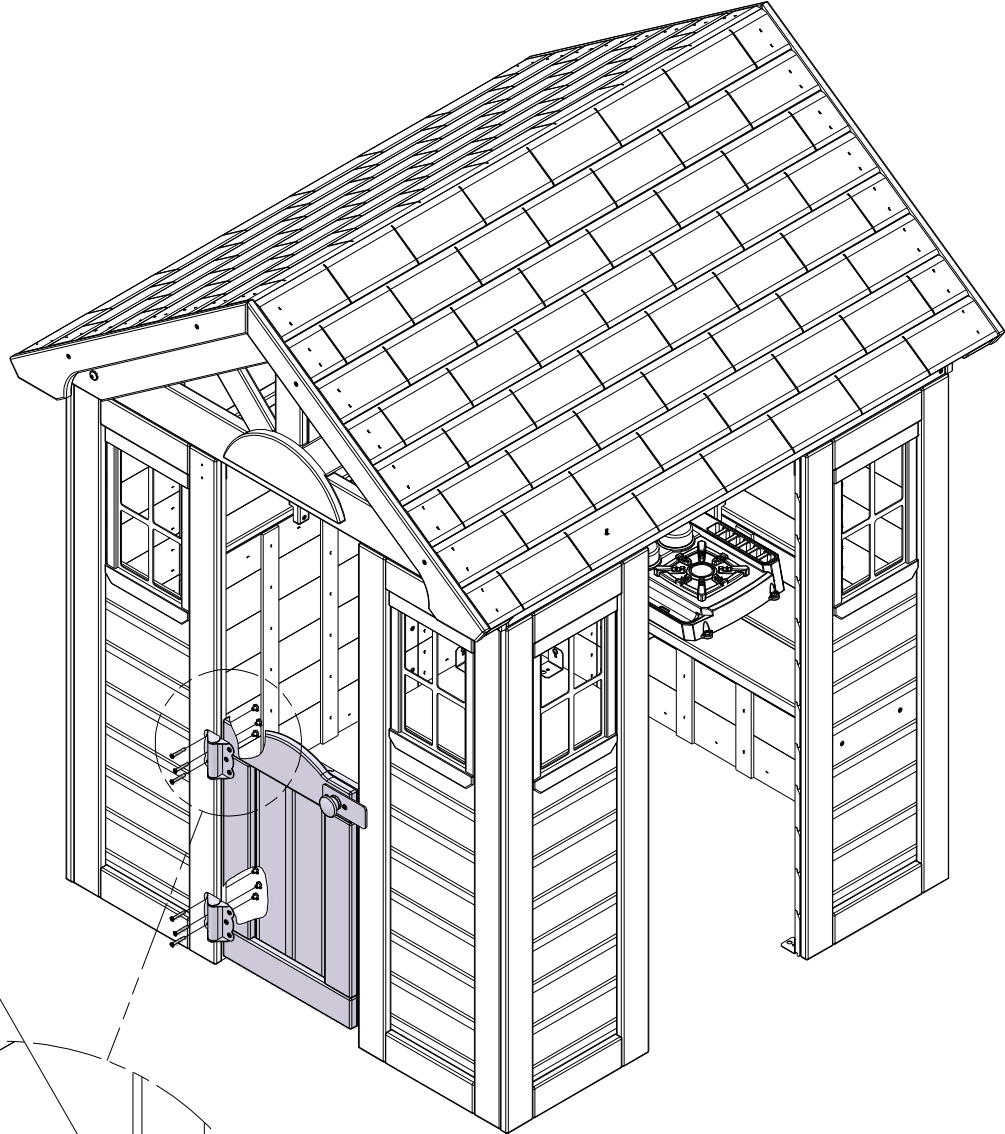

804 (x6)
T-NUT - 8/32"

806 (x6)
SCREW - 1 1/8"

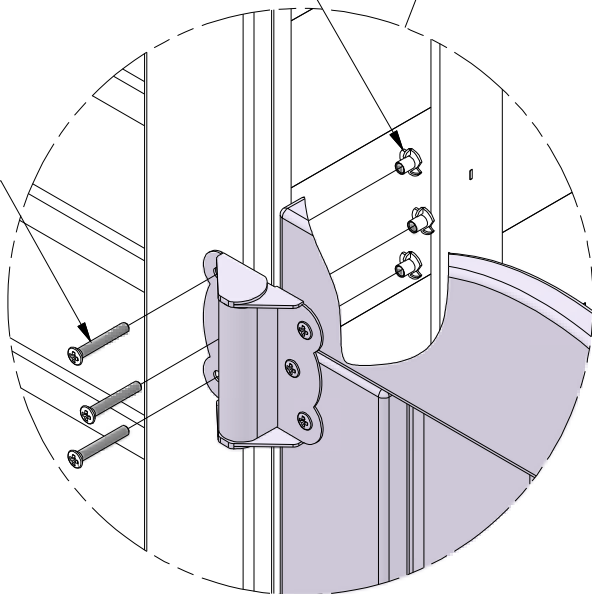

STEP 24 - PLAYHOUSE ASSEMBLY

QTY	PART NUMBER	DESCRIPTION
2	H100797	SCREW PWH 8x1 BLK

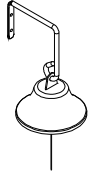

A4M01045
(x1) BELL ASSEMBLY

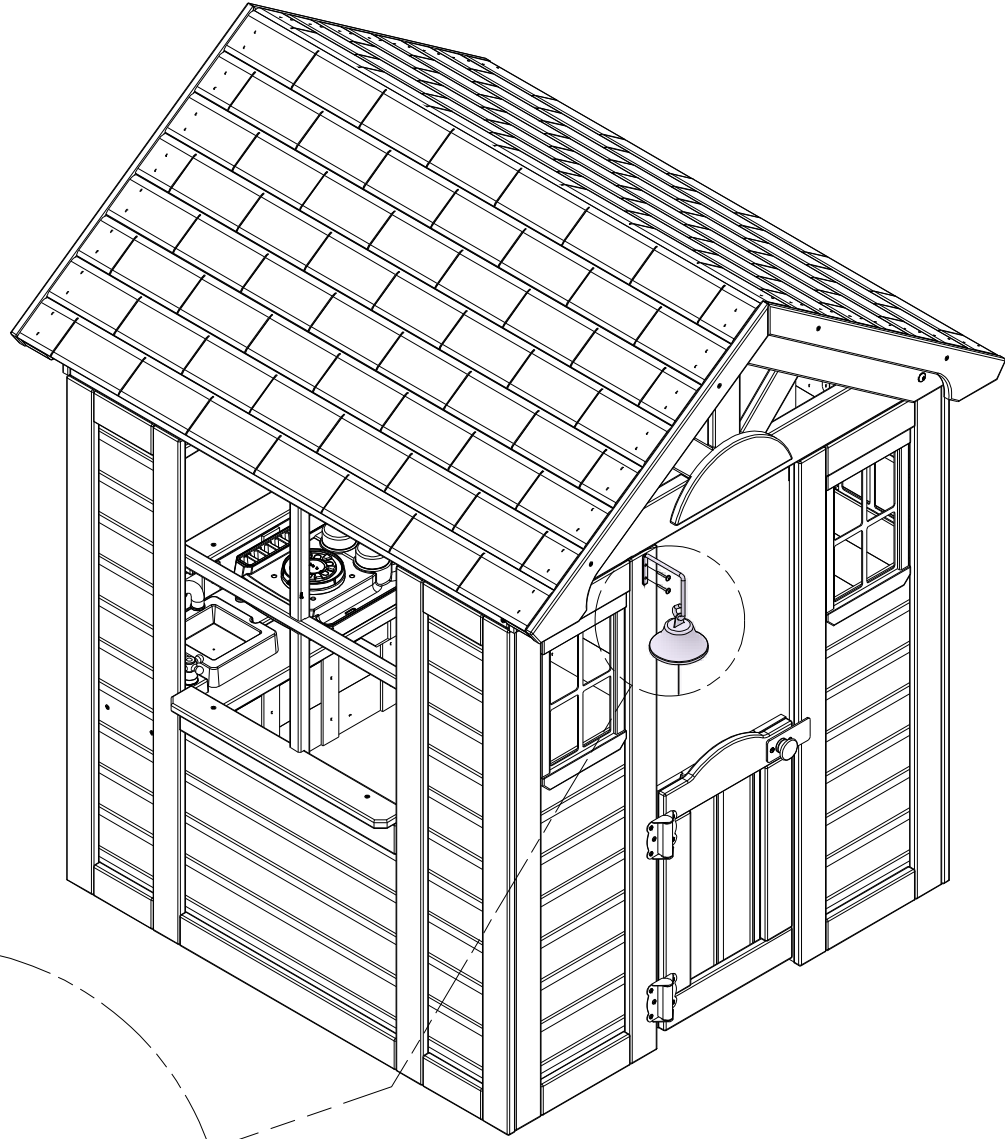

797 *(x2)*
SCREW - 1"

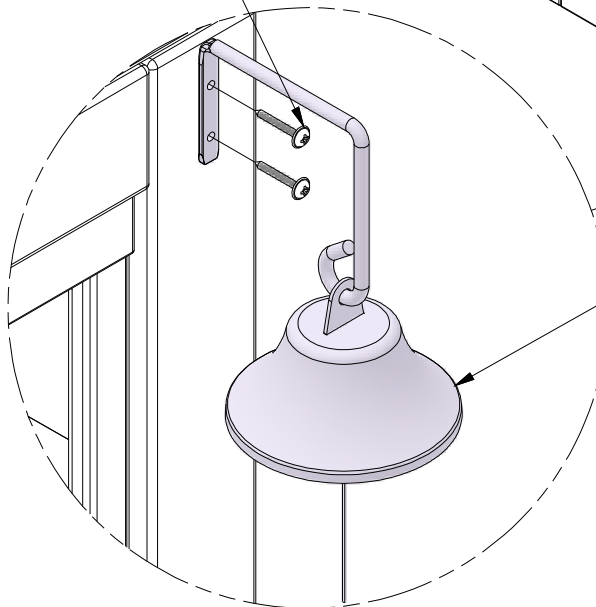

045 *(x1)*
BELL ASSEMBLY

STEP 1 - FINAL ASSEMBLY

QTY	PART NUMBER	DESCRIPTION
2	H100198	WASHER LOCK EXT 8x19 BLK
2	H100378	BOLT WH 5/16x1 3/4 BLK

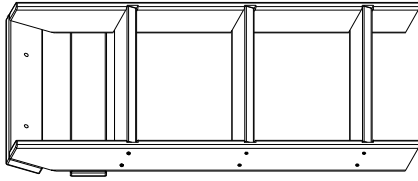

(x1) LADDER SUBASSEMBLY

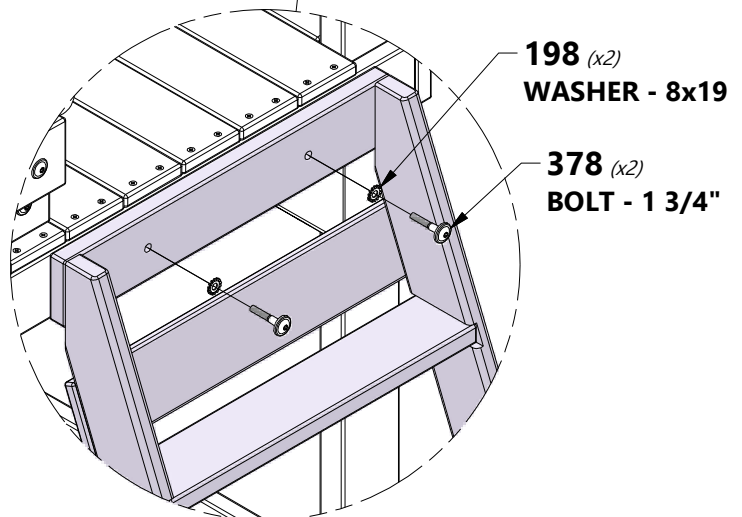
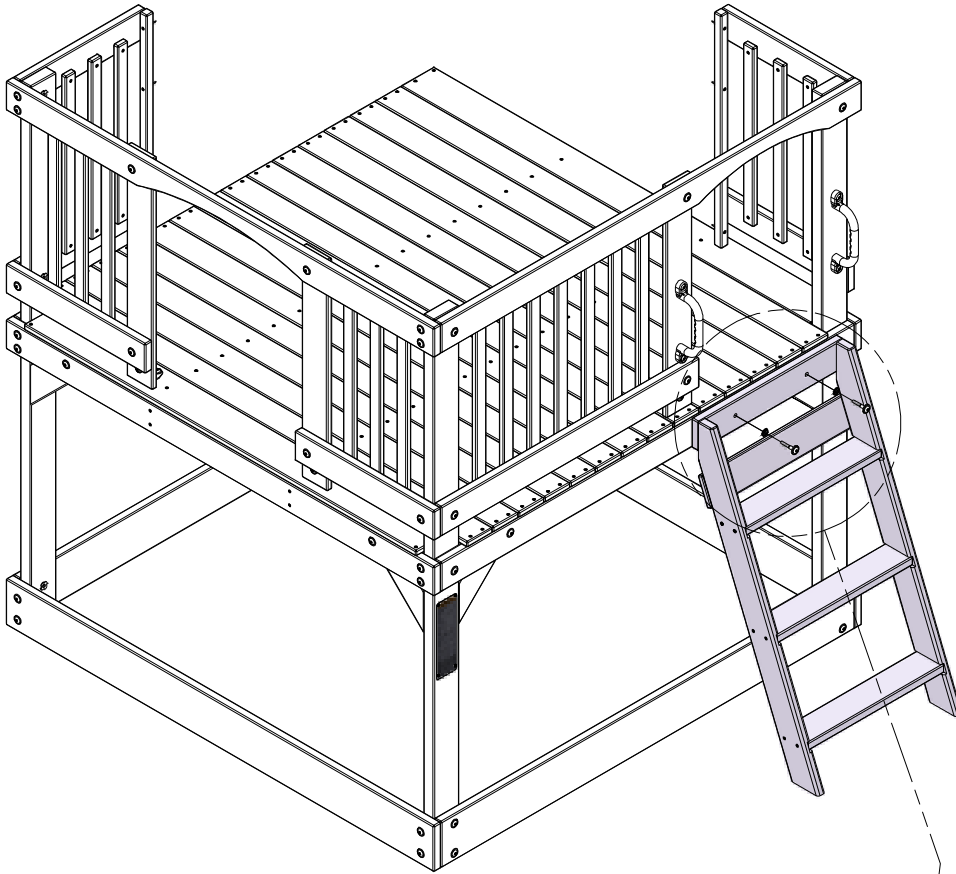

STEP 2 - FINAL ASSEMBLY

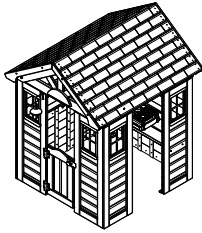

(x1) PLAYHOUSE SUBASSEMBLY

QTY	PART NUMBER	DESCRIPTION
8	H100382	SCREW PFH 8x1 3/4 BLK
8	H100408	SCREW PWH 8x1/2 BLK

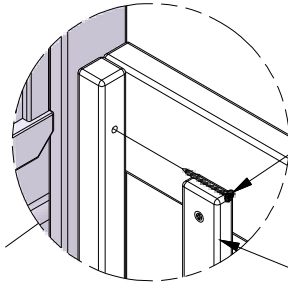
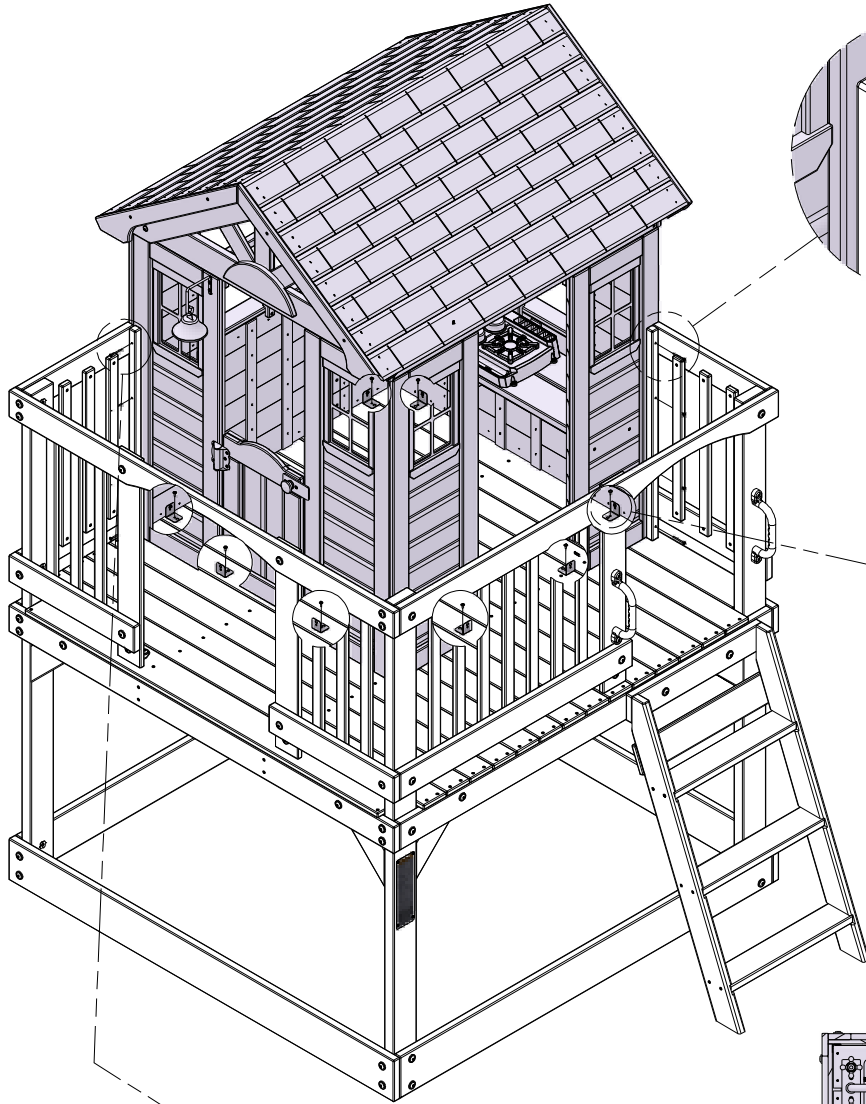

382 (x4)
SCREW - 1 3/4"

PICKET MAY NEED TO BE TEMPORARILY REMOVED TO ASSEMBLE THE HOUSE TO THE DECK.

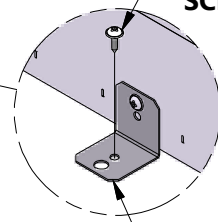

408 (x8)
SCREW - 1/2"

555
90° L-BRACKET - BLK
(ASSEMBLED PREVIOUSLY)

TOP VIEW

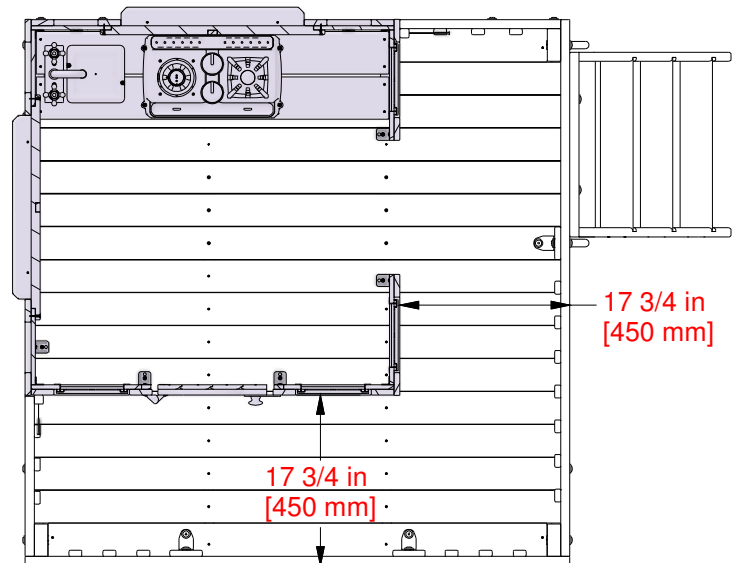

17 3/4 in
[450 mm]

17 3/4 in
[450 mm]

382 (x4)
SCREW - 1 3/4"

PICKET MAY NEED TO BE TEMPORARILY REMOVED TO ASSEMBLE THE HOUSE TO THE DECK.

STEP 3 - FINAL ASSEMBLY



A4M00528 BYD ID TAG (MEDIUM) AGES 2 TO 10
(x1)

QTY	PART NUMBER	DESCRIPTION
2	H100202	SCREW PWH 8x5/8 BLK

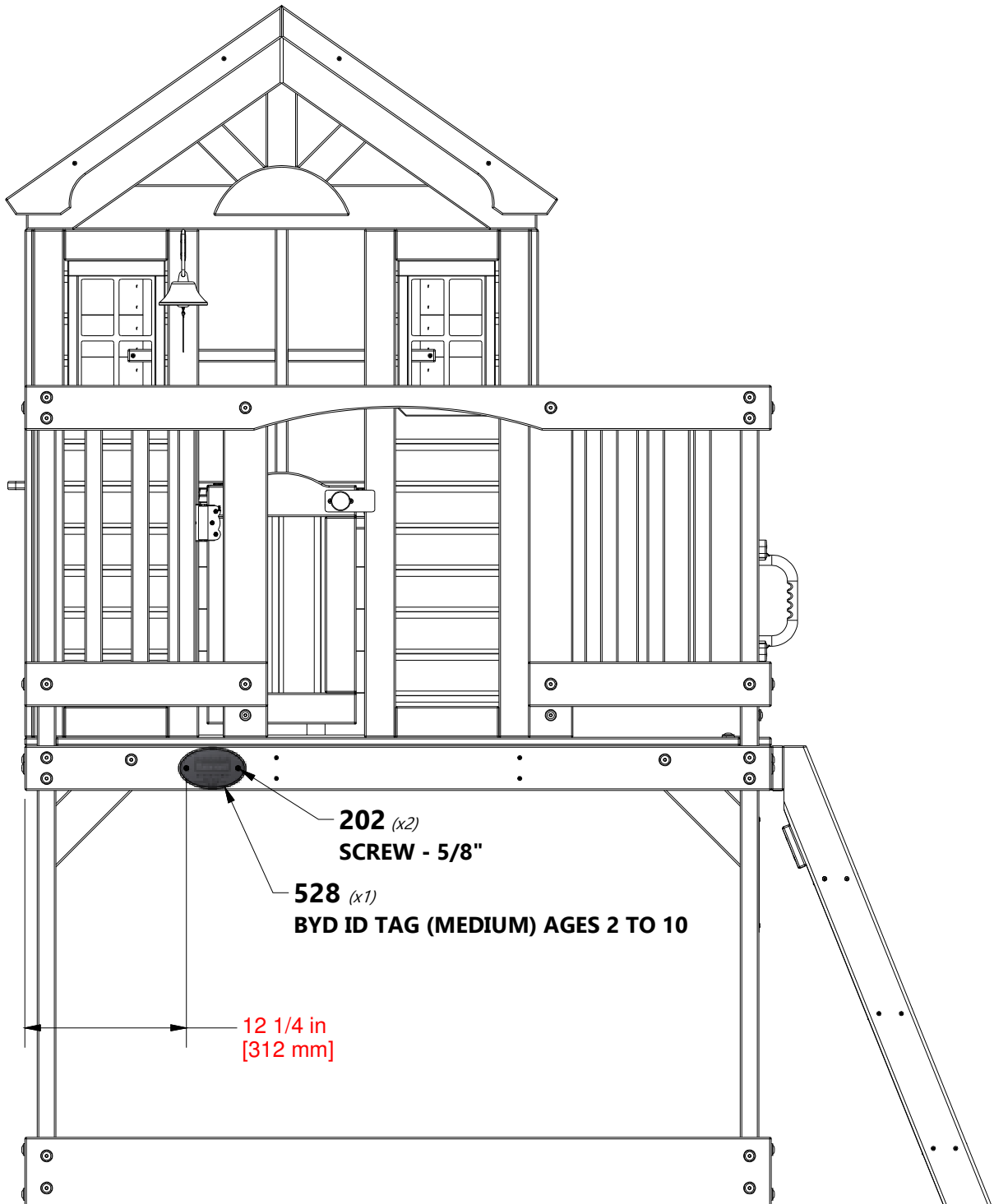

STEP 4 - FINAL ASSEMBLY

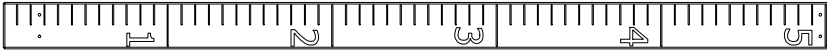

QTY	PART NUMBER	DESCRIPTION
4	H100380	SCREW PFH 8x1 1/8 BLK

M1 GROWTH BOARD - W4L17864
(x1) 5/8"x3 3/8"x60 1/4" (16x86x1530)

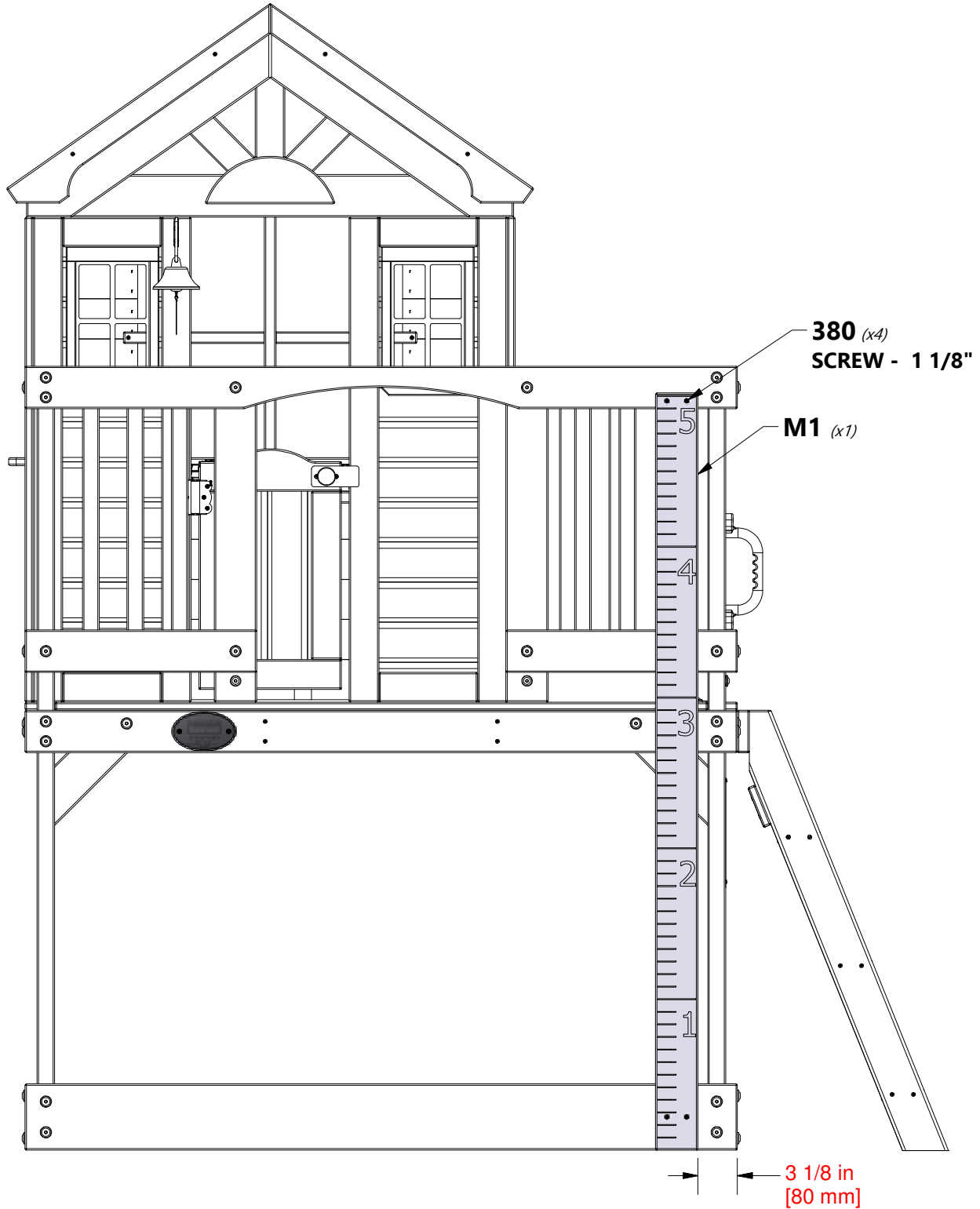

STEP 5 - FINAL ASSEMBLY

QTY	PART NUMBER	DESCRIPTION
2	H100379	T-NUT 5/16 BLK
2	H100396	BOLT WH 5/16x1/2 BLK

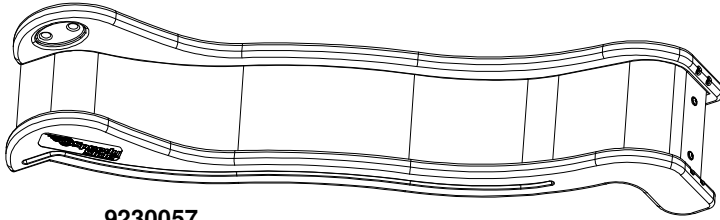

9230057
(x1) **6 FT SPEEDY SLIDE**

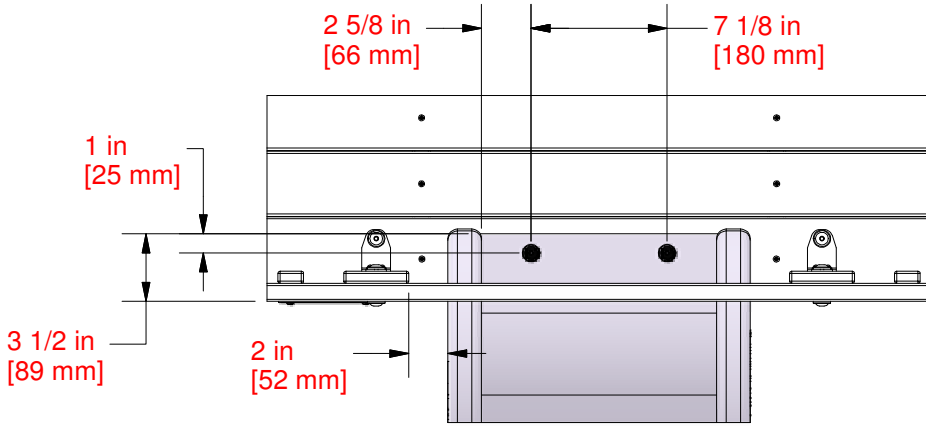

DRILLING LOCATIONS

CENTER SLIDE IN OPENING. DRILL (2) 3/8" [10mm] HOLES THRU SLIDE BED AND DECK WHERE SHOWN FOR HARDWARE.

396 (x2)
BOLT - 1/2"

379 (x2)
T-NUT - 5/16"

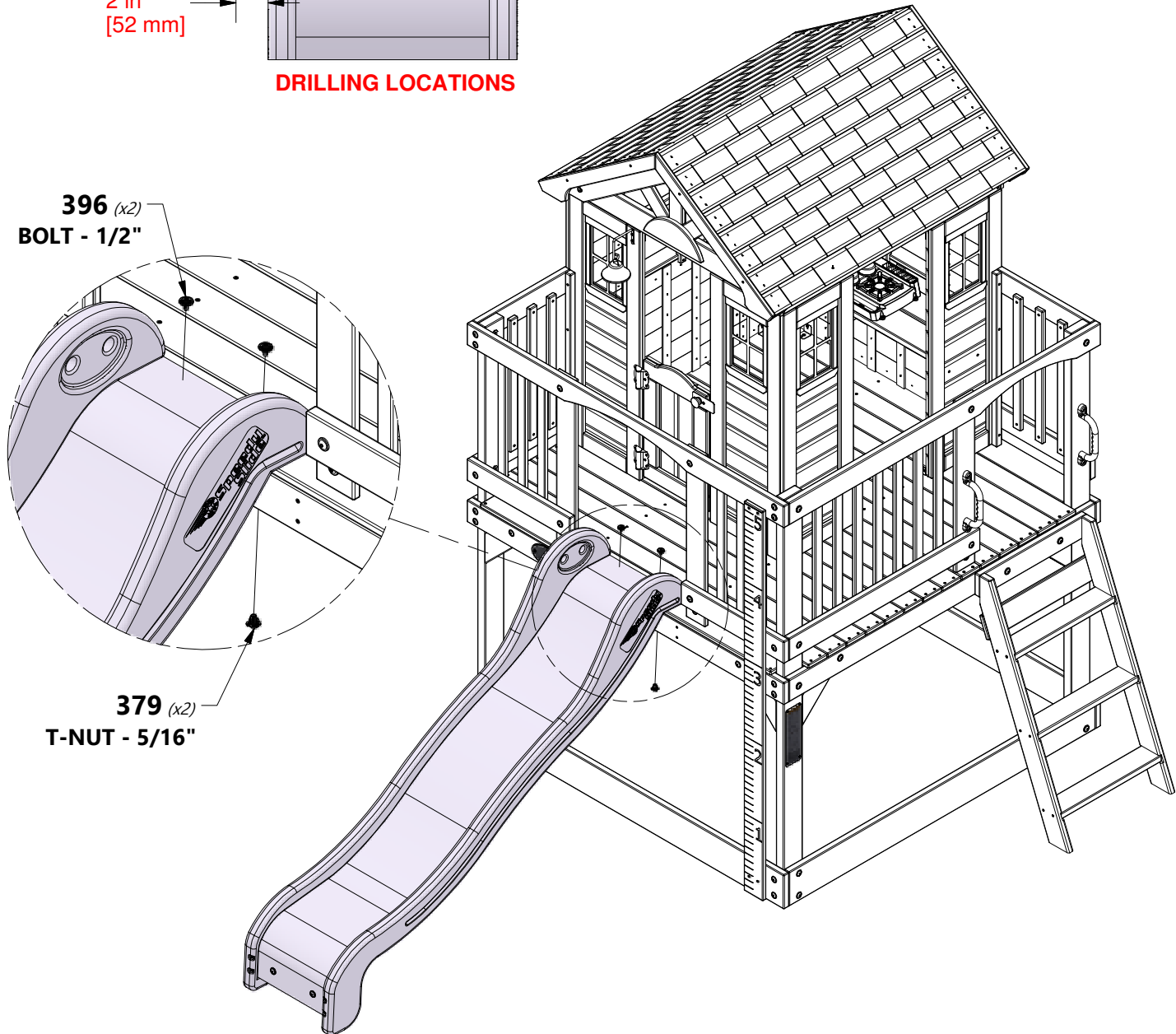

STEP 6 - FINAL ASSEMBLY

QTY	PART NUMBER	DESCRIPTION
4	H100199	WASHER LOCK EXT 12x19 BLK
4	H100468	BOLT WH 5/16x1 BLK
4	H100469	NUT BARREL WH 5/16x5/8 BLK



NOTE:
FAILURE TO USE GROUND STAKES CAN
VOID WARRANTY & CAUSE INJURY!

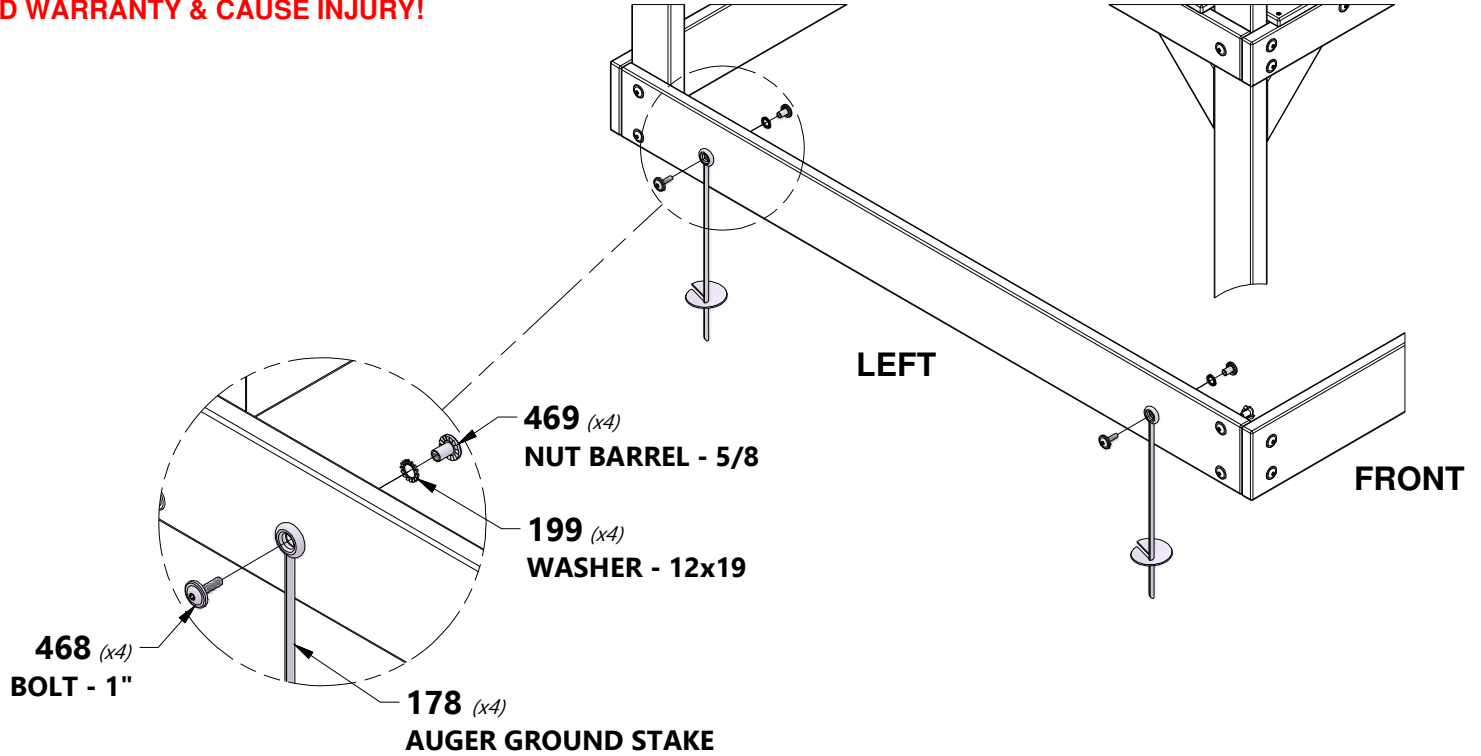

TWIST GROUND STAKES INTO GROUND IN LOCATIONS SHOWN.
USING GROUND STAKE AS A GUIDE, DRILL 7/16" [11 mm] HOLE FOR HARDWARE.

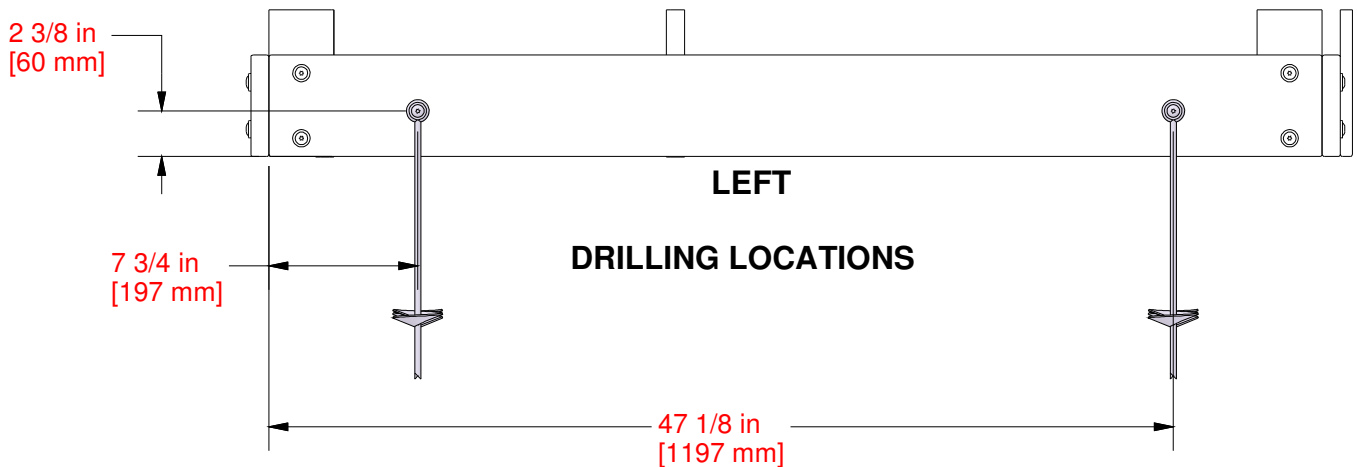

*****PERFORM THE SAME ASSEMBLY PROCESS FOR THE RIGHT SIDE.*****